

**Model**  
**Name: 8I915MD-GV**

SHEET	TITLE
01	COVER SHEET
02	BLOCK DIAGRAM
03	BOM & PCB MODIFY HISTORY
04	P4_LGA775_A
05	P4_LGA775_B
06	P4_LGA775_C
07	P4_LGA775_D
08	VCORE POWER
09	GMCH-GRANTS DALE_HOST
10	GMCH-GARNTSDALE_DDR
11	GMCH-GRANTS DALE_PCI E, DMI
12	GMCH-GRANTS DALE_INT VGA
13	GMCH-GRANTS DALE_GND
14	GMCH-GRANTS DALE_PWR
15	DDR II CHANNEL A,B
16	DDR II TERMINATION
17	PCI EXPRESS*16 SLOT
18	ICH6 PCI, USB, DMI, LAN
19	ICH6 IDE, GPIO, SATA, CTRL
20	ICH6 VCC, GND
21	CLK GEN
22	PCI SLOT

SHEET	TITLE
23	ITE8712IX
24	HWMO, FAN
25	KB_MS
26	COM, LPT, FDD
27	(FRONT+REAR) USB, RING, IDE
28	CODEC ALC655
29	AUDIO JACK
30	ATX POWER CONN., BIOS
31	ALL POWER
32	LAN REALTEK RTL8100C
33	FRONT PANEL, BZ, PROCHOT
34	GPIO TABLE
35	RESET TABLE

 COMPONENT SIDE  
 (1 oz. Copper)  
 VCC SIDE  
 (1 oz. Copper)  
 GND SIDE  
 (1 oz. Copper)  
 SOLDER SIDE  
 (1 oz. Copper)

<b>GIGABYTE</b>		
Title <b>Cover Sheet</b>		
Size Custom	Document Number <b>8I915MD-GV</b>	Rev <b>1.0</b>
Date: Friday, September 02, 2005	Sheet 1	of 35

# BLOCK DIAGRAM

**INTEL Pentium4 LGA775**  
 VCCORE = 1.75V / SLEEP : 1.3V  
 VCC3  
 PAGE 4, 5, 6, 7

**CLOCK GENERATOR**  
 CKVDD = 3.3V  
 PAGE 22

**PWM/OTHER POWER**  
 VCCORE = 1.75V (650-1100MHz) / SLEEP : 1.3V  
 5VSB = 12V / +12V, VCC, VCC3, 3VDDUAL  
 VTT\_DDR2 = 2.5VSTR  
 PAGE 8, 34, 35

**GMCH GRANTSDALE**  
 VCCORE = 1.75V / SLEEP : 1.3V  
 2.5VSTR = 2.5V(MEMORY,SUSPEND POWER)  
 VDDQ = 1.5V (AGP POWER 4X, HUBLINK)  
 PAGE 9, 10, 11, 12, 13, 14

**CHANNEL A**  
 DDRII DIMM X 1  
 DDRI DIMM X 1  
 2.5VSTR = 2.5V(MEMORY,SUSPEND POWER)  
 VTT\_DDR = 1.25V  
 PAGE 15, 17

**CHANNEL B**  
 DDRII DIMM X 1  
 DDRI DIMM X 1  
 2.5VSTR = 2.5V(MEMORY,SUSPEND POWER)  
 VTT\_DDR = 1.25V  
 PAGE 16, 17

**PCI EXPRESS BY 16 PORTS**  
 VDDQ = 1.5V (AGP POWER 4X)  
 VCC3 = 3.3V  
 +12V = 12V  
 3VDDUAL = 3.3V  
 VCC = 5V  
 PAGE 18

GAD0-31  
 ADSTB0, ADSTB0-  
 ADSTB1, ADSTB1-  
 SBA0-7  
 SBSTB, SBSTB-  
 GCBE0-3-  
 ST0-2

MAA0-14  
 MAA\_CPC1-5  
 MAB\_CPC1-5  
 MDD0-63  
 -DQSD0-7  
 DM0-7

HLO-10  
 CONTROL BUS HUB LINK

**ICH6**  
 VCC25 = 2.5V(I/O, MEMORY, VLINK)  
 3VDDUAL = 3.3V(SUSPEND POWER)  
 VCC3 = 3.3V  
 RTVDD = 3.3V  
 PAGE 19, 20, 21

**IDE Primary**  
 VCC = 5V  
 PAGE 29

**SERIAL ATA**  
 VCC = 5V  
 PAGE 20

**USB PORTS 0~7**  
 VCC = 5V  
 5VSB = 5V  
 5VUSB = 5V  
 PAGE 29

**FWH/HWMO**  
 VCC = 5V  
 VCC3 = 3V  
 PAGE 26

**PCI SLOT  
 PCI EXPRESS SLOT**  
 +12 = 12V  
 -12 = -12V  
 VCC = 5V  
 VCC3 = 3V  
 3VDDUAL = 3V  
 PAGE 23, 24

**LAN BCM5721/5751**  
 PAGE 32, 33

**1394 IT TSB43AB23**  
 PAGE 36

**RAID VIA6410**  
 PAGE 38, 39

**LPC ITE8712HX**  
 VCC = 5V  
 5VSB = 5V  
 VBAT = 3V  
 PAGE 25

**I/O PORTS :**  
 COMA COMB LPT PS2 IR FDD  
 PAGE 27, 28, 29

**AC97/Azalia  
 ALC880/CMI9880**  
 +12V = 12V  
 VCC3 = 3.3V  
 VCC = 5V  
 AVDD = 5V  
 PAGE 30

AZALIA LINK

**AUDIO PORTS :** FRONT AUDIO  
 LIN\_ OUT LINE\_IN MIC  
 TELE CD\_IN AUX\_IN  
 PAGE 31

**FRONT PANEL/BZ**  
 VCC = 5V  
 5VSB = 5V  
 +12 = 12V  
 PVCC = 5V  
 PAGE 37

AGPUSB+ / -

AMRUSB+ / -

<b>GIGABYTE</b>			
<b>BOM &amp; PCB MODIFY HISTORY</b>			
File			
Size	Document Number	81915MD-GV	Rev
Custom			1.0
Date	Friday, September 02, 2005	Sheet	2 of 35



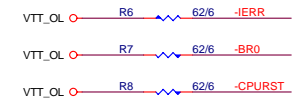
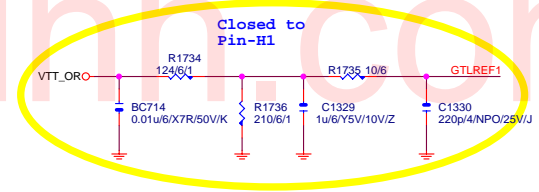
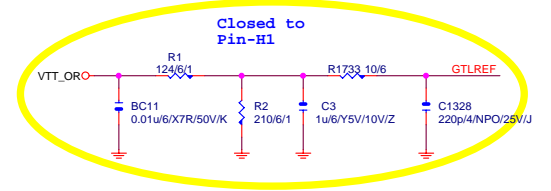
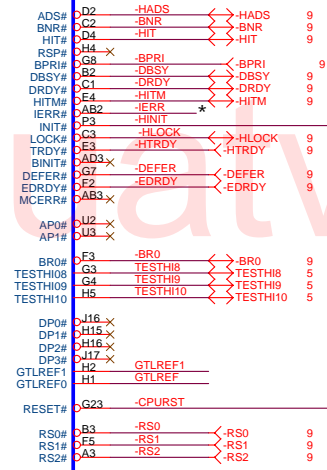
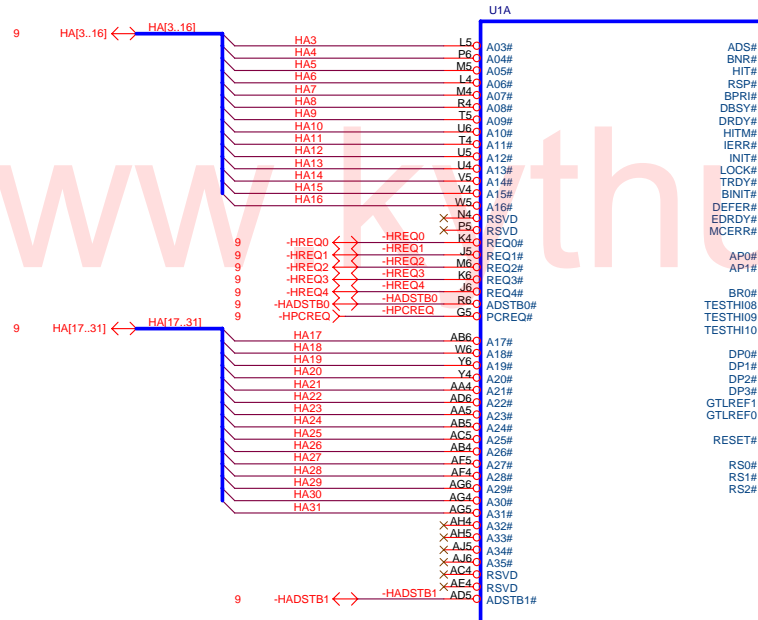

CPU-SK/BK/775/D/GF/[11SC1-920775-02R]

CR  
CPU RETAINTION/X

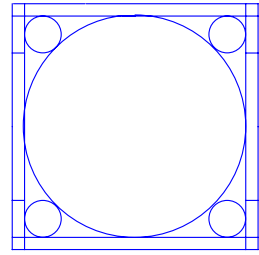

<b>GIGABYTE</b>		
Title <b>P4_LGA775-A</b>		
Size Custom	Document Number <b>8I915MD-GV</b>	Rev <b>1.0</b>
Date: Friday, September 02, 2005	Sheet 4	of 35

10UH/120mA/B/S/[10LI2-12100A-02\_10LI2-12100A-13]

**Note:**  
VCCA & VCOREPLL  
define doesn't same as  
old P4 design kit



Trace width doesn't  
less than 12 Mil

10UH/120mA/B/S/[10LI2-12100A-02\_10LI2-12100A-13]

As close as possible to  
CPU socket

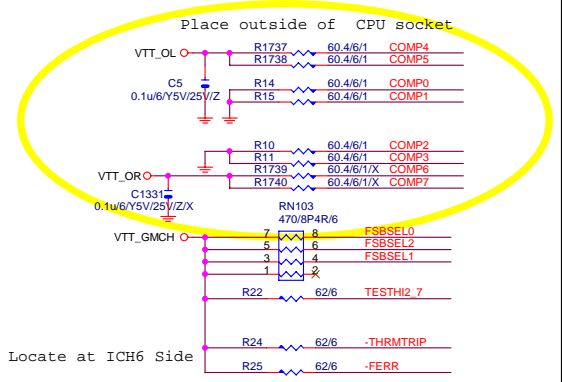
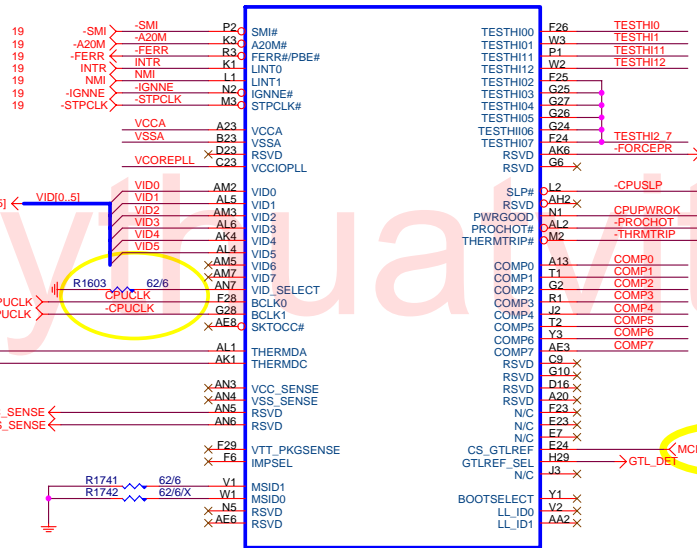
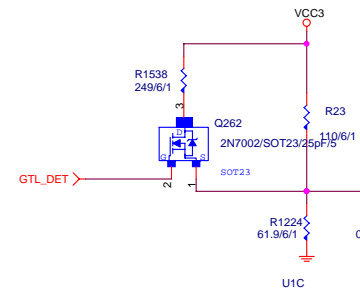
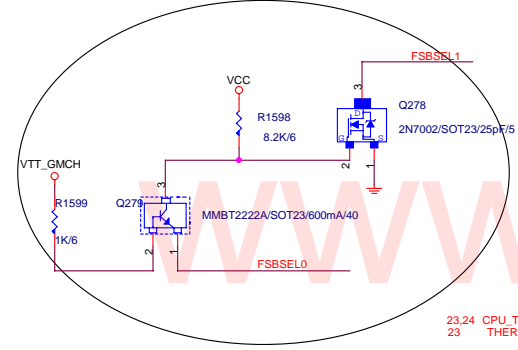

Locate at ICH6 Side

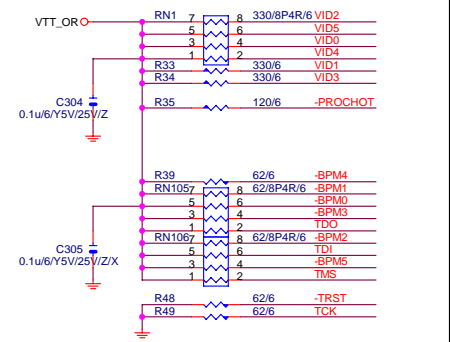
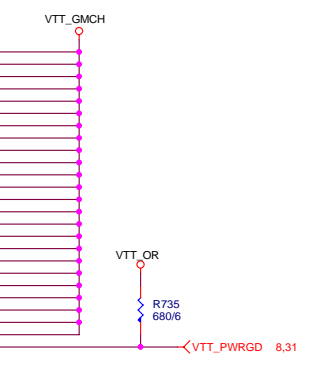
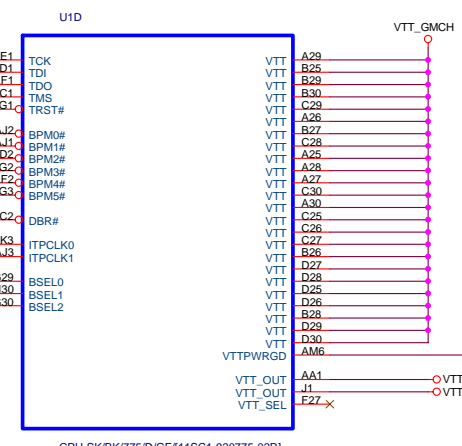
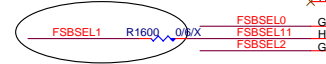
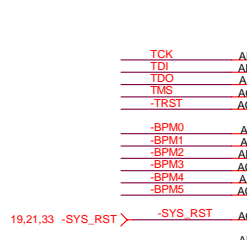
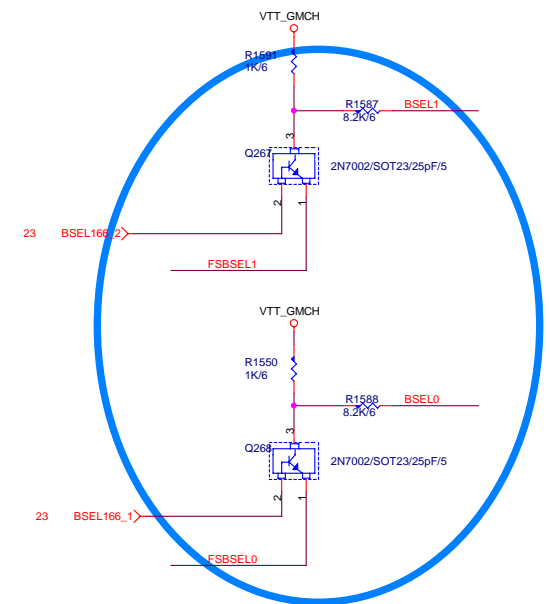
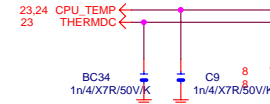
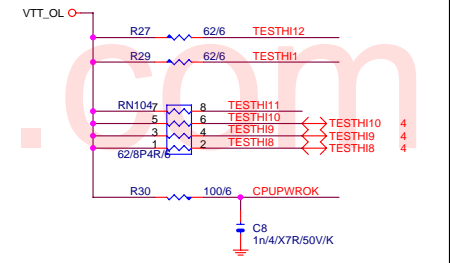

www.tntvittinh.com

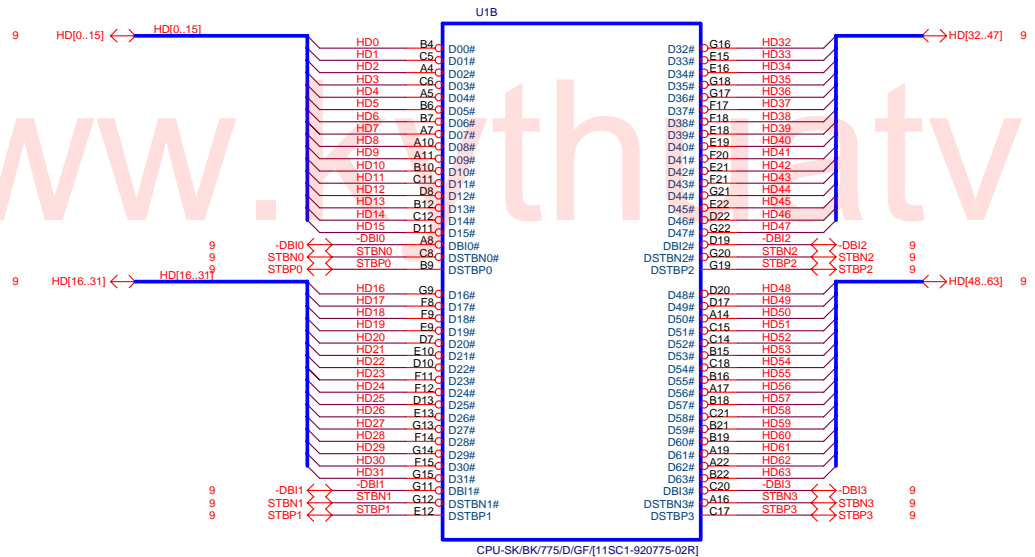

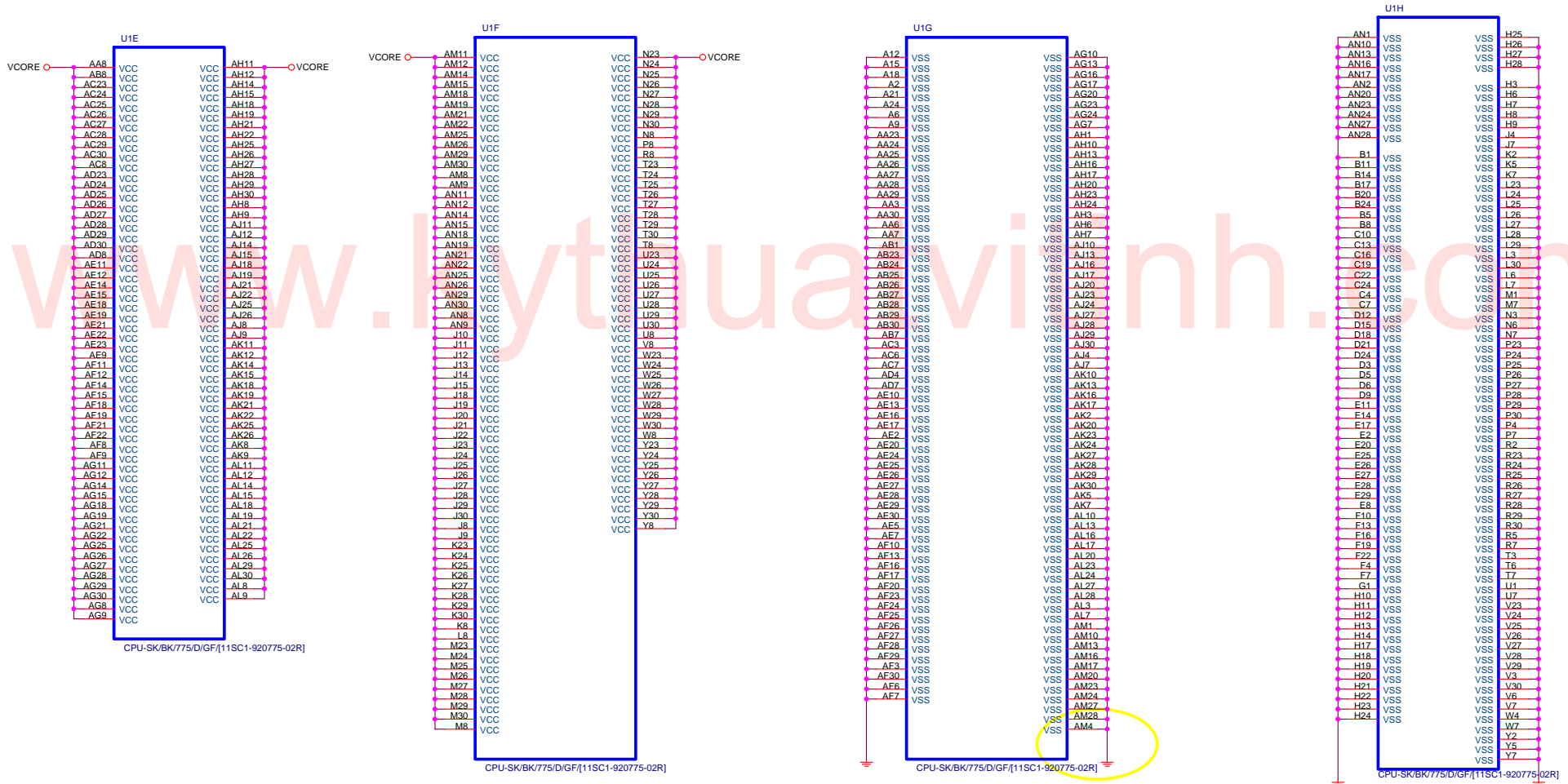

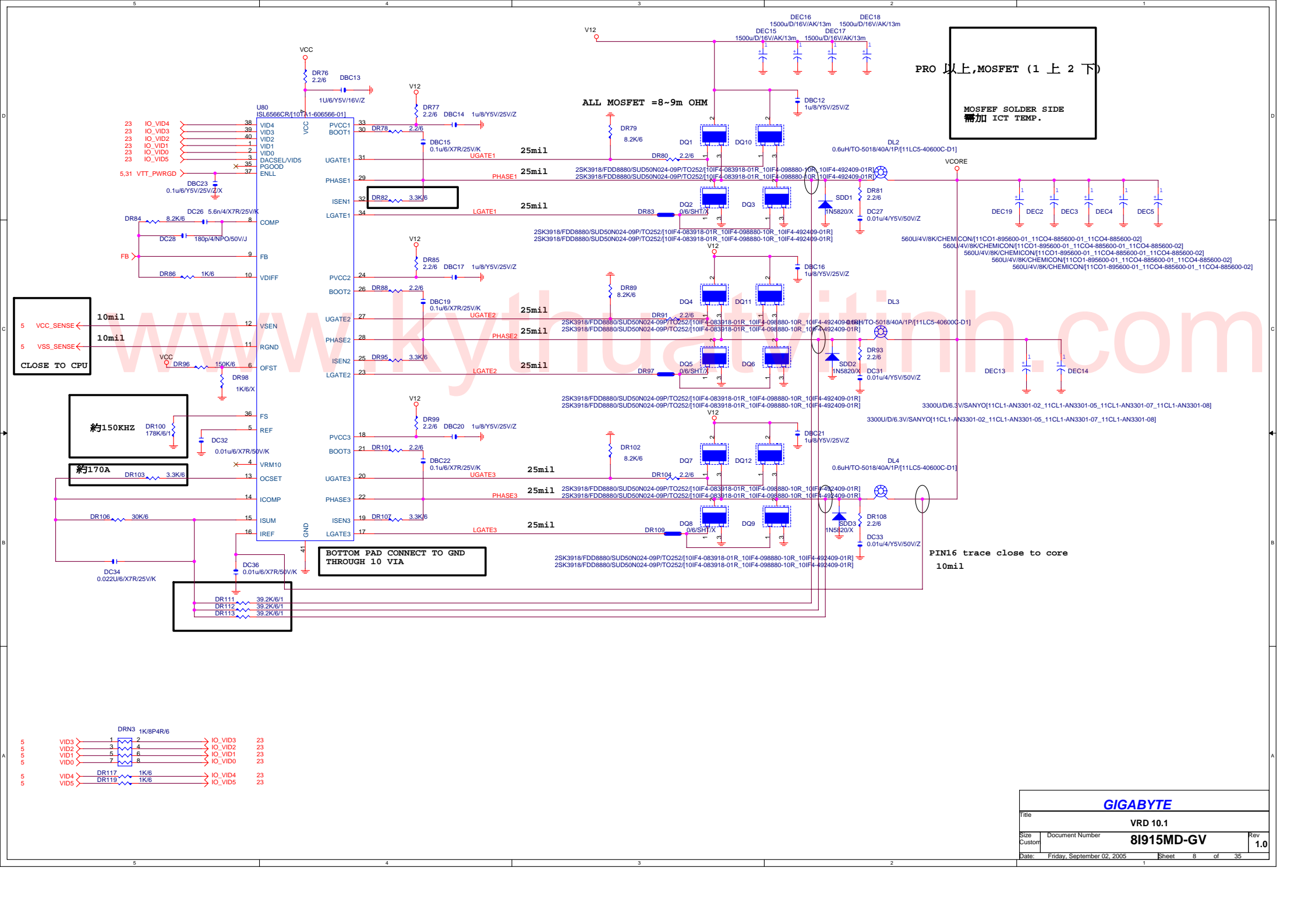

PRO 以上, MOSFET (1上2下)  
MOSFET SOLDER SIDE  
需加 ICT TEMP.

VCC\_SENSE ← 10mil  
VSS\_SENSE ← 10mil  
CLOSE TO CPU

約150KHZ  
約170A

BOTTOM PAD CONNECT TO GND  
THROUGH 10 VIA

PIN16 trace close to core  
10mil

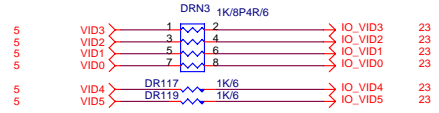

<b>GIGABYTE</b>			
Title <b>VRD 10.1</b>			
Size	Document Number	<b>81915MD-GV</b>	
Custom			Rev <b>1.0</b>
Date:	Friday, September 02, 2005	Sheet	8 of 35



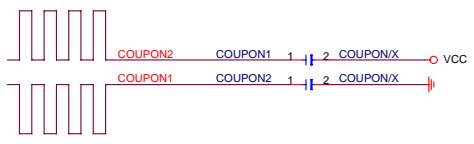
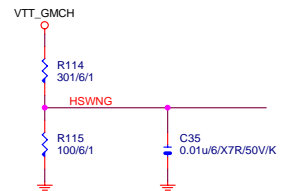
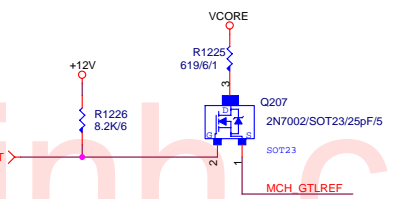
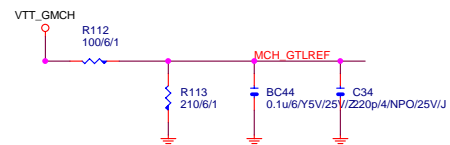
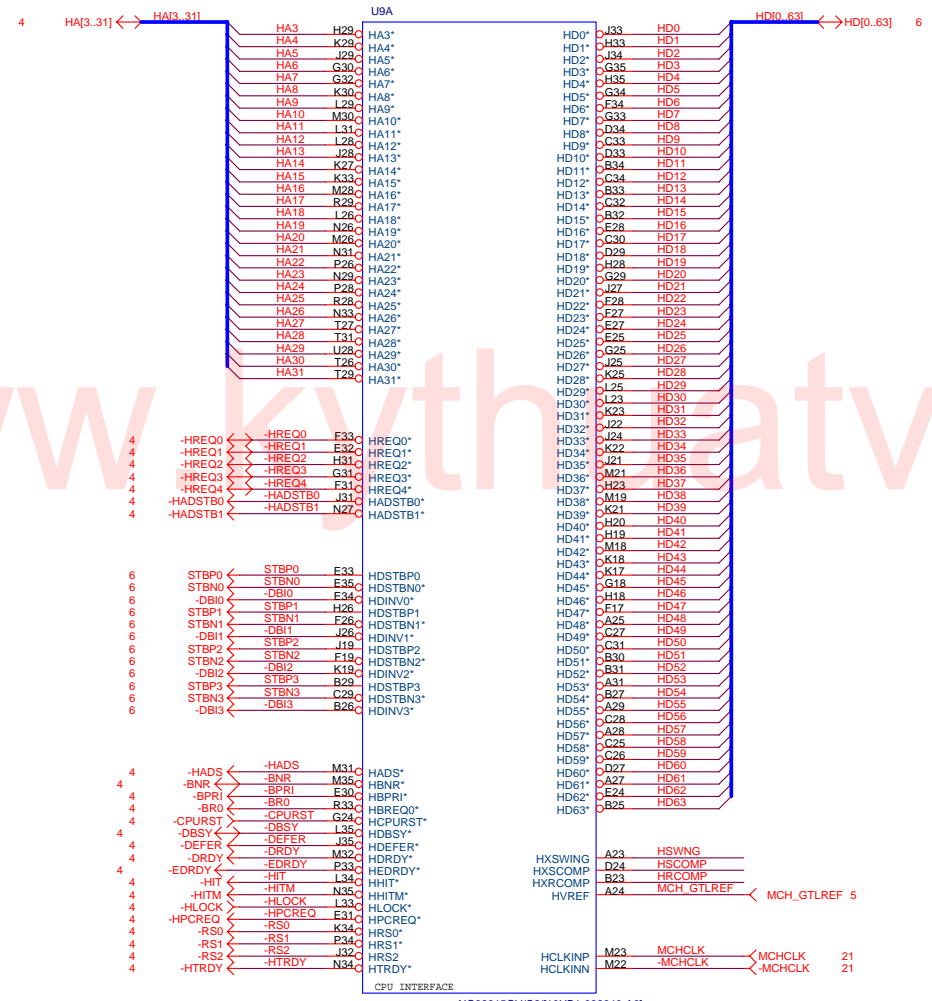

<b>GIGABYTE</b>			
Title: <b>GMCH-HOST</b>			
Size	Document Number	<b>81915MD-GV</b>	Rev
Custom			<b>1.0</b>
Date:	Friday, September 02, 2005	Sheet	9 of 35

USE			
MAAA0	AP26	SAMA0	SADQ00
MAAA1	AR24	SAMA1	SADQ01
MAAA2	AL24	SAMA2	SADQ02
MAAA3	AP23	SAMA3	SADQ03
MAAA4	AP22	SAMA4	SADQ04
MAAA5	AN23	SAMA5	SADQ05
MAAA6	AN23	SAMA6	SADQ06
MAAA7	AP21	SAMA7	SADQ07
MAAA8	AN21	SAMA8	SADQ08
MAAA9	AN21	SAMA9	SADQ09
MAAA10	AM27	SAMA10	SADQ10
MAAA11	AM21	SAMA11	SADQ11
MAAA12	AR20	SAMA12	SADQ12
MAAA13	AP31	SAMA13	SADQ13
MAAA14	AP31	SAMA14	SADQ14
MAAA15	AP31	SAMA15	SADQ15
MAAA16	AP31	SAMA16	SADQ16
MAAA17	AP31	SAMA17	SADQ17
MAAA18	AP31	SAMA18	SADQ18
MAAA19	AP31	SAMA19	SADQ19
MAAA20	AP31	SAMA20	SADQ20
MAAA21	AP31	SAMA21	SADQ21
MAAA22	AP31	SAMA22	SADQ22
MAAA23	AP31	SAMA23	SADQ23
MAAA24	AP31	SAMA24	SADQ24
MAAA25	AP31	SAMA25	SADQ25
MAAA26	AP31	SAMA26	SADQ26
MAAA27	AP31	SAMA27	SADQ27
MAAA28	AP31	SAMA28	SADQ28
MAAA29	AP31	SAMA29	SADQ29
MAAA30	AP31	SAMA30	SADQ30
MAAA31	AP31	SAMA31	SADQ31
MAAA32	AP31	SAMA32	SADQ32
MAAA33	AP31	SAMA33	SADQ33
MAAA34	AP31	SAMA34	SADQ34
MAAA35	AP31	SAMA35	SADQ35
MAAA36	AP31	SAMA36	SADQ36
MAAA37	AP31	SAMA37	SADQ37
MAAA38	AP31	SAMA38	SADQ38
MAAA39	AP31	SAMA39	SADQ39
MAAA40	AP31	SAMA40	SADQ40
MAAA41	AP31	SAMA41	SADQ41
MAAA42	AP31	SAMA42	SADQ42
MAAA43	AP31	SAMA43	SADQ43
MAAA44	AP31	SAMA44	SADQ44
MAAA45	AP31	SAMA45	SADQ45
MAAA46	AP31	SAMA46	SADQ46
MAAA47	AP31	SAMA47	SADQ47
MAAA48	AP31	SAMA48	SADQ48
MAAA49	AP31	SAMA49	SADQ49
MAAA50	AP31	SAMA50	SADQ50
MAAA51	AP31	SAMA51	SADQ51
MAAA52	AP31	SAMA52	SADQ52
MAAA53	AP31	SAMA53	SADQ53
MAAA54	AP31	SAMA54	SADQ54
MAAA55	AP31	SAMA55	SADQ55
MAAA56	AP31	SAMA56	SADQ56
MAAA57	AP31	SAMA57	SADQ57
MAAA58	AP31	SAMA58	SADQ58
MAAA59	AP31	SAMA59	SADQ59
MAAA60	AP31	SAMA60	SADQ60
MAAA61	AP31	SAMA61	SADQ61
MAAA62	AP31	SAMA62	SADQ62
MAAA63	AP31	SAMA63	SADQ63
MAAA64	AP31	SAMA64	SADQ64
MAAA65	AP31	SAMA65	SADQ65
MAAA66	AP31	SAMA66	SADQ66
MAAA67	AP31	SAMA67	SADQ67
MAAA68	AP31	SAMA68	SADQ68
MAAA69	AP31	SAMA69	SADQ69
MAAA70	AP31	SAMA70	SADQ70
MAAA71	AP31	SAMA71	SADQ71
MAAA72	AP31	SAMA72	SADQ72
MAAA73	AP31	SAMA73	SADQ73
MAAA74	AP31	SAMA74	SADQ74
MAAA75	AP31	SAMA75	SADQ75
MAAA76	AP31	SAMA76	SADQ76
MAAA77	AP31	SAMA77	SADQ77
MAAA78	AP31	SAMA78	SADQ78
MAAA79	AP31	SAMA79	SADQ79
MAAA80	AP31	SAMA80	SADQ80
MAAA81	AP31	SAMA81	SADQ81
MAAA82	AP31	SAMA82	SADQ82
MAAA83	AP31	SAMA83	SADQ83
MAAA84	AP31	SAMA84	SADQ84
MAAA85	AP31	SAMA85	SADQ85
MAAA86	AP31	SAMA86	SADQ86
MAAA87	AP31	SAMA87	SADQ87
MAAA88	AP31	SAMA88	SADQ88
MAAA89	AP31	SAMA89	SADQ89
MAAA90	AP31	SAMA90	SADQ90
MAAA91	AP31	SAMA91	SADQ91
MAAA92	AP31	SAMA92	SADQ92
MAAA93	AP31	SAMA93	SADQ93
MAAA94	AP31	SAMA94	SADQ94
MAAA95	AP31	SAMA95	SADQ95
MAAA96	AP31	SAMA96	SADQ96
MAAA97	AP31	SAMA97	SADQ97
MAAA98	AP31	SAMA98	SADQ98
MAAA99	AP31	SAMA99	SADQ99
MAA000	AP31	SAMA000	SADQ000

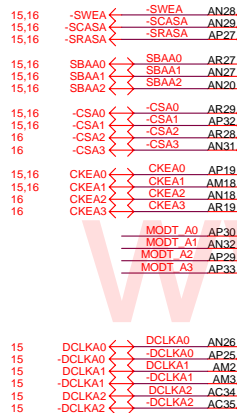

Trace Lenth Need < 200mils  
Trace Width Need = 5mils  
Trace Space Need > 10mils

U9F			
MAAB0	AM15	SAMA0	SADQ00
MAAB1	AR15	SAMA1	SADQ01
MAAB2	AN15	SAMA2	SADQ02
MAAB3	AP14	SAMA3	SADQ03
MAAB4	AL15	SAMA4	SADQ04
MAAB5	AM12	SAMA5	SADQ05
MAAB6	AP13	SAMA6	SADQ06
MAAB7	AL12	SAMA7	SADQ07
MAAB8	AN13	SAMA8	SADQ08
MAAB9	AR12	SAMA9	SADQ09
MAAB10	AP15	SAMA10	SADQ10
MAAB11	AP11	SAMA11	SADQ11
MAAB12	AR11	SAMA12	SADQ12
MAAB13	AL33	SAMA13	SADQ13
MAAB14	AP17	SAMA14	SADQ14
MAAB15	AP18	SAMA15	SADQ15
MAAB16	AP19	SAMA16	SADQ16
MAAB17	AP20	SAMA17	SADQ17
MAAB18	AP21	SAMA18	SADQ18
MAAB19	AP22	SAMA19	SADQ19
MAAB20	AP23	SAMA20	SADQ20
MAAB21	AP24	SAMA21	SADQ21
MAAB22	AP25	SAMA22	SADQ22
MAAB23	AP26	SAMA23	SADQ23
MAAB24	AP27	SAMA24	SADQ24
MAAB25	AP28	SAMA25	SADQ25
MAAB26	AP29	SAMA26	SADQ26
MAAB27	AP30	SAMA27	SADQ27
MAAB28	AP31	SAMA28	SADQ28
MAAB29	AP32	SAMA29	SADQ29
MAAB30	AP33	SAMA30	SADQ30
MAAB31	AP34	SAMA31	SADQ31
MAAB32	AP35	SAMA32	SADQ32
MAAB33	AP36	SAMA33	SADQ33
MAAB34	AP37	SAMA34	SADQ34
MAAB35	AP38	SAMA35	SADQ35
MAAB36	AP39	SAMA36	SADQ36
MAAB37	AP40	SAMA37	SADQ37
MAAB38	AP41	SAMA38	SADQ38
MAAB39	AP42	SAMA39	SADQ39
MAAB40	AP43	SAMA40	SADQ40
MAAB41	AP44	SAMA41	SADQ41
MAAB42	AP45	SAMA42	SADQ42
MAAB43	AP46	SAMA43	SADQ43
MAAB44	AP47	SAMA44	SADQ44
MAAB45	AP48	SAMA45	SADQ45
MAAB46	AP49	SAMA46	SADQ46
MAAB47	AP50	SAMA47	SADQ47
MAAB48	AP51	SAMA48	SADQ48
MAAB49	AP52	SAMA49	SADQ49
MAAB50	AP53	SAMA50	SADQ50
MAAB51	AP54	SAMA51	SADQ51
MAAB52	AP55	SAMA52	SADQ52
MAAB53	AP56	SAMA53	SADQ53
MAAB54	AP57	SAMA54	SADQ54
MAAB55	AP58	SAMA55	SADQ55
MAAB56	AP59	SAMA56	SADQ56
MAAB57	AP60	SAMA57	SADQ57
MAAB58	AP61	SAMA58	SADQ58
MAAB59	AP62	SAMA59	SADQ59
MAAB60	AP63	SAMA60	SADQ60
MAAB61	AP64	SAMA61	SADQ61
MAAB62	AP65	SAMA62	SADQ62
MAAB63	AP66	SAMA63	SADQ63
MAAB64	AP67	SAMA64	SADQ64
MAAB65	AP68	SAMA65	SADQ65
MAAB66	AP69	SAMA66	SADQ66
MAAB67	AP70	SAMA67	SADQ67
MAAB68	AP71	SAMA68	SADQ68
MAAB69	AP72	SAMA69	SADQ69
MAAB70	AP73	SAMA70	SADQ70
MAAB71	AP74	SAMA71	SADQ71
MAAB72	AP75	SAMA72	SADQ72
MAAB73	AP76	SAMA73	SADQ73
MAAB74	AP77	SAMA74	SADQ74
MAAB75	AP78	SAMA75	SADQ75
MAAB76	AP79	SAMA76	SADQ76
MAAB77	AP80	SAMA77	SADQ77
MAAB78	AP81	SAMA78	SADQ78
MAAB79	AP82	SAMA79	SADQ79
MAAB80	AP83	SAMA80	SADQ80
MAAB81	AP84	SAMA81	SADQ81
MAAB82	AP85	SAMA82	SADQ82
MAAB83	AP86	SAMA83	SADQ83
MAAB84	AP87	SAMA84	SADQ84
MAAB85	AP88	SAMA85	SADQ85
MAAB86	AP89	SAMA86	SADQ86
MAAB87	AP90	SAMA87	SADQ87
MAAB88	AP91	SAMA88	SADQ88
MAAB89	AP92	SAMA89	SADQ89
MAAB90	AP93	SAMA90	SADQ90
MAAB91	AP94	SAMA91	SADQ91
MAAB92	AP95	SAMA92	SADQ92
MAAB93	AP96	SAMA93	SADQ93
MAAB94	AP97	SAMA94	SADQ94
MAAB95	AP98	SAMA95	SADQ95
MAAB96	AP99	SAMA96	SADQ96
MAAB97	AP100	SAMA97	SADQ97
MAAB98	AP101	SAMA98	SADQ98
MAAB99	AP102	SAMA99	SADQ99
MAAB000	AP103	SAMA000	SADQ000

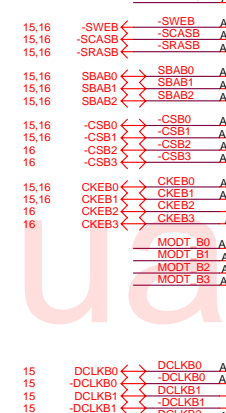

Trace Lenth Need < 200mils  
Trace Width Need = 5mils  
Trace Space Need > 10mils

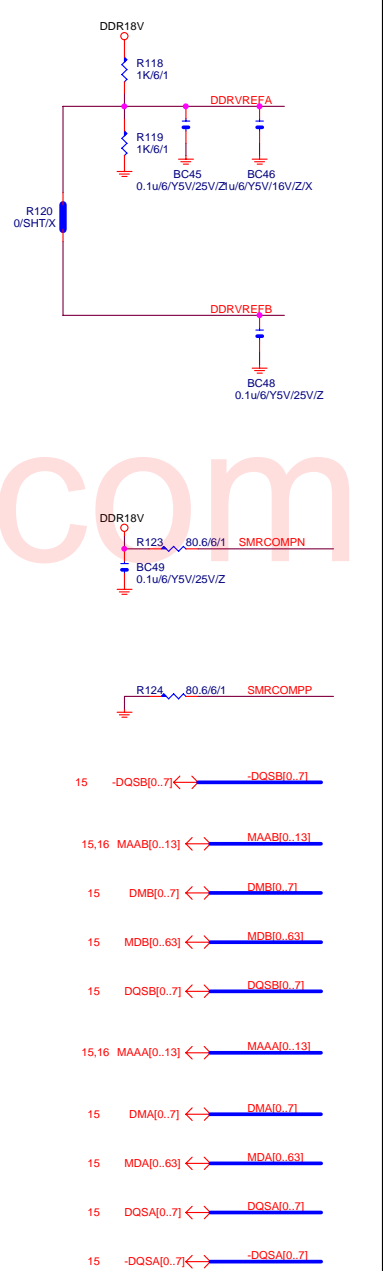

Trace Length Need < 1.5"  
Trace Width Need > 10mils  
Trace Space Need > 10mils



**GIGABYTE**

Title: **GMCH-DDR**

Size Custom Document Number: **81915MD-GV** Rev: **1.0**

Date: Friday, September 02, 2005 Sheet 10 of 35

20:5:7:5:20

www.vitinh.com

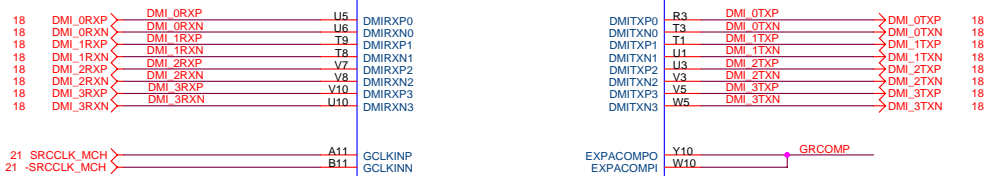
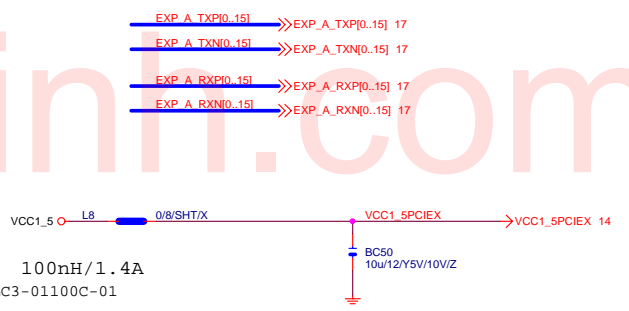
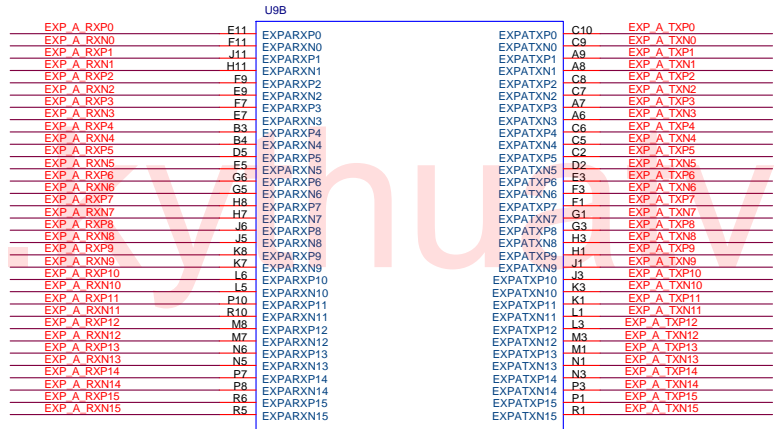

For DVO Function NG82915GV/C2[10HB1-032940-A6]

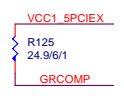

<b>GIGABYTE</b>		
Title <b>GMCH-PCI E &amp; DMI</b>		
Size Custom	Document Number <b>8I915MD-GV</b>	Rev <b>1.0</b>
Date: Friday, September 02, 2005	Sheet 11	of 35

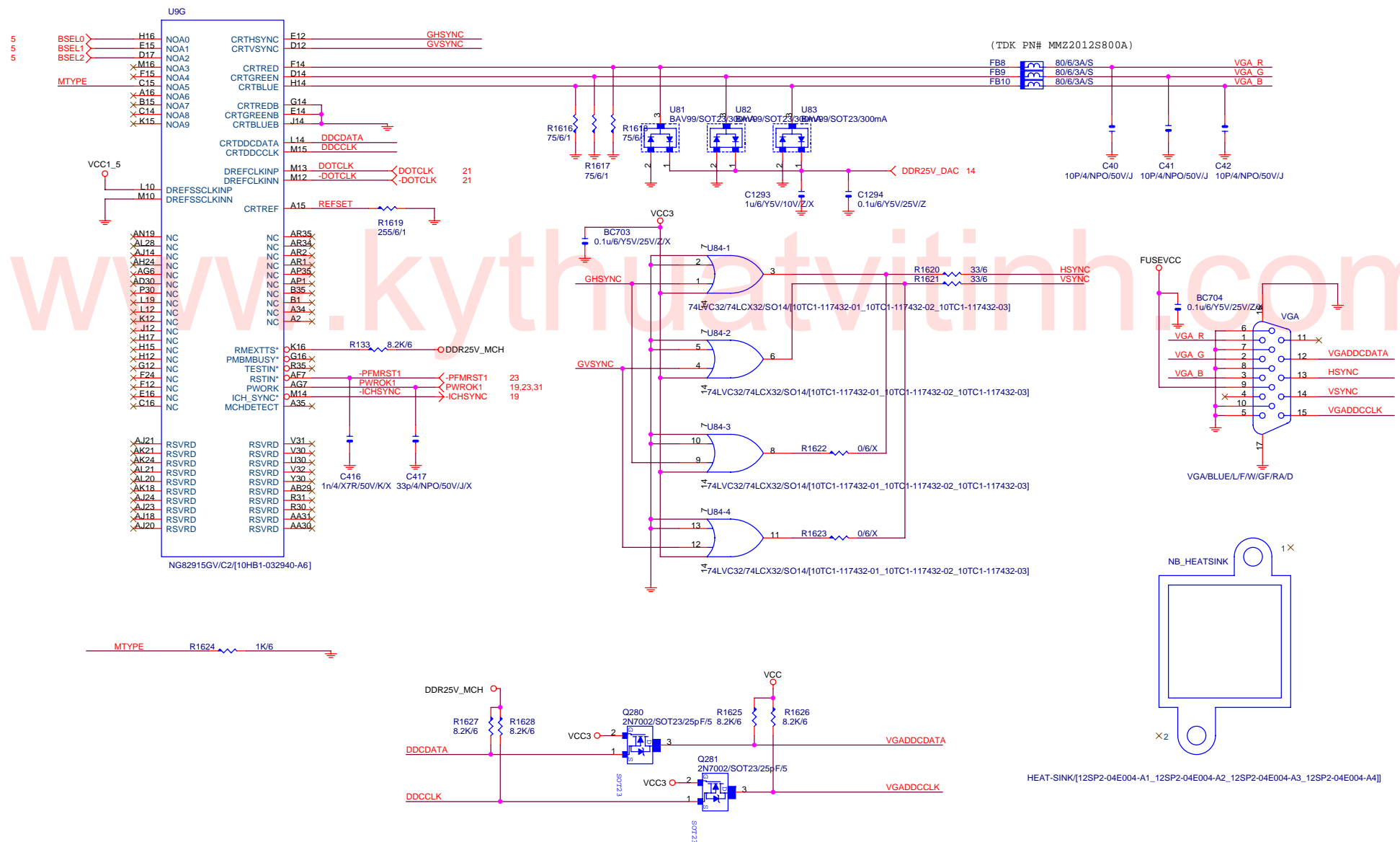

<b>GIGABYTE</b>		
Title	<b>GMCH-INTERNAL VGA</b>	
Size	Document Number	<b>8I915MD-GV</b>
Custom		Rev <b>1.0</b>
Date:	Friday, September 02, 2005	Sheet 12 of 35

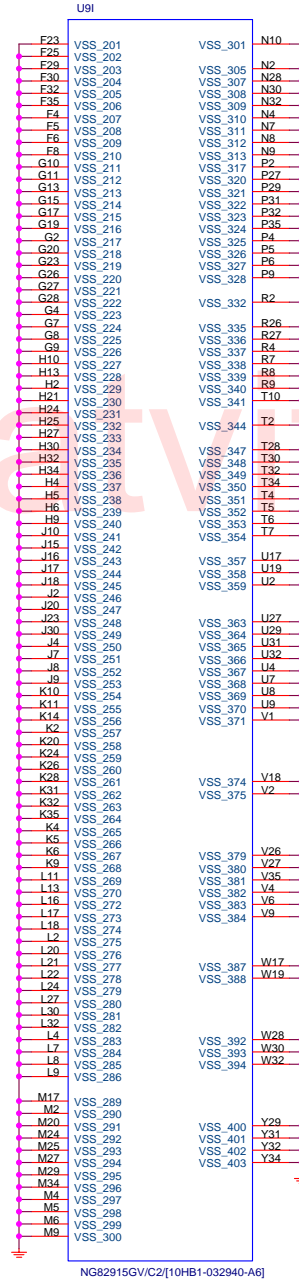
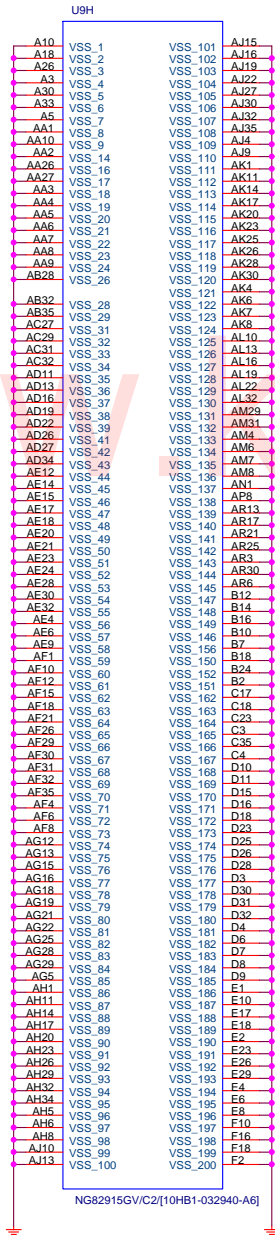

<b>GIGABYTE</b>		
Title <b>GMCH-GND</b>		
Size Custom	Document Number <b>8I915MD-GV</b>	Rev <b>1.0</b>
Date:	Friday, September 02, 2005	Sheet 13 of 35

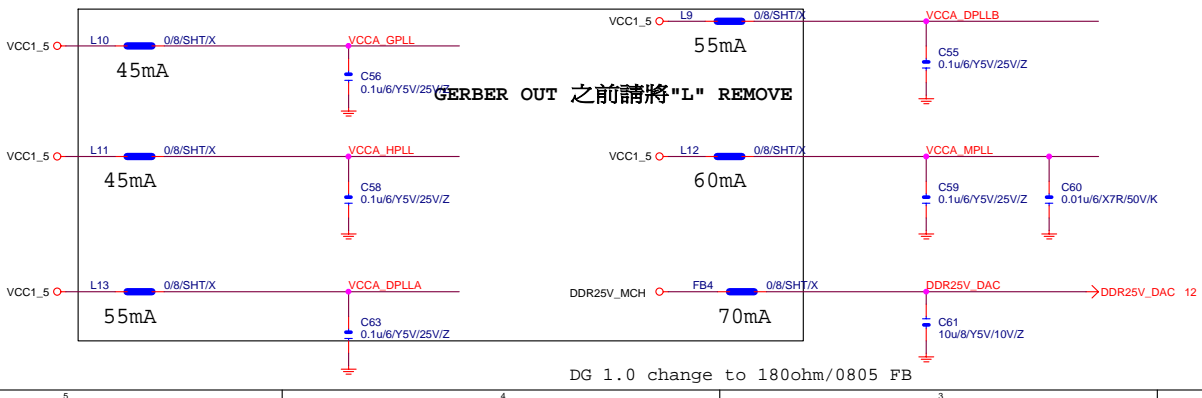
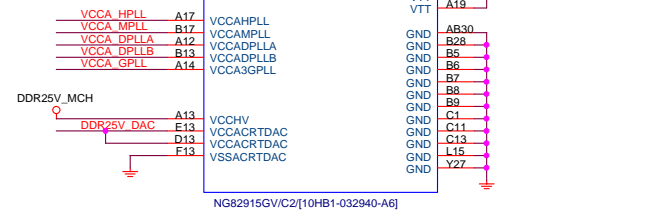
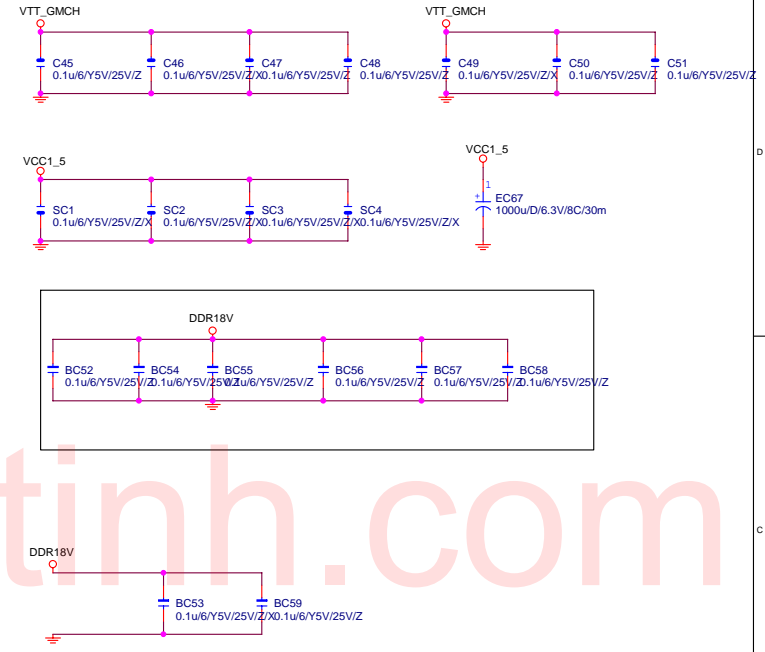
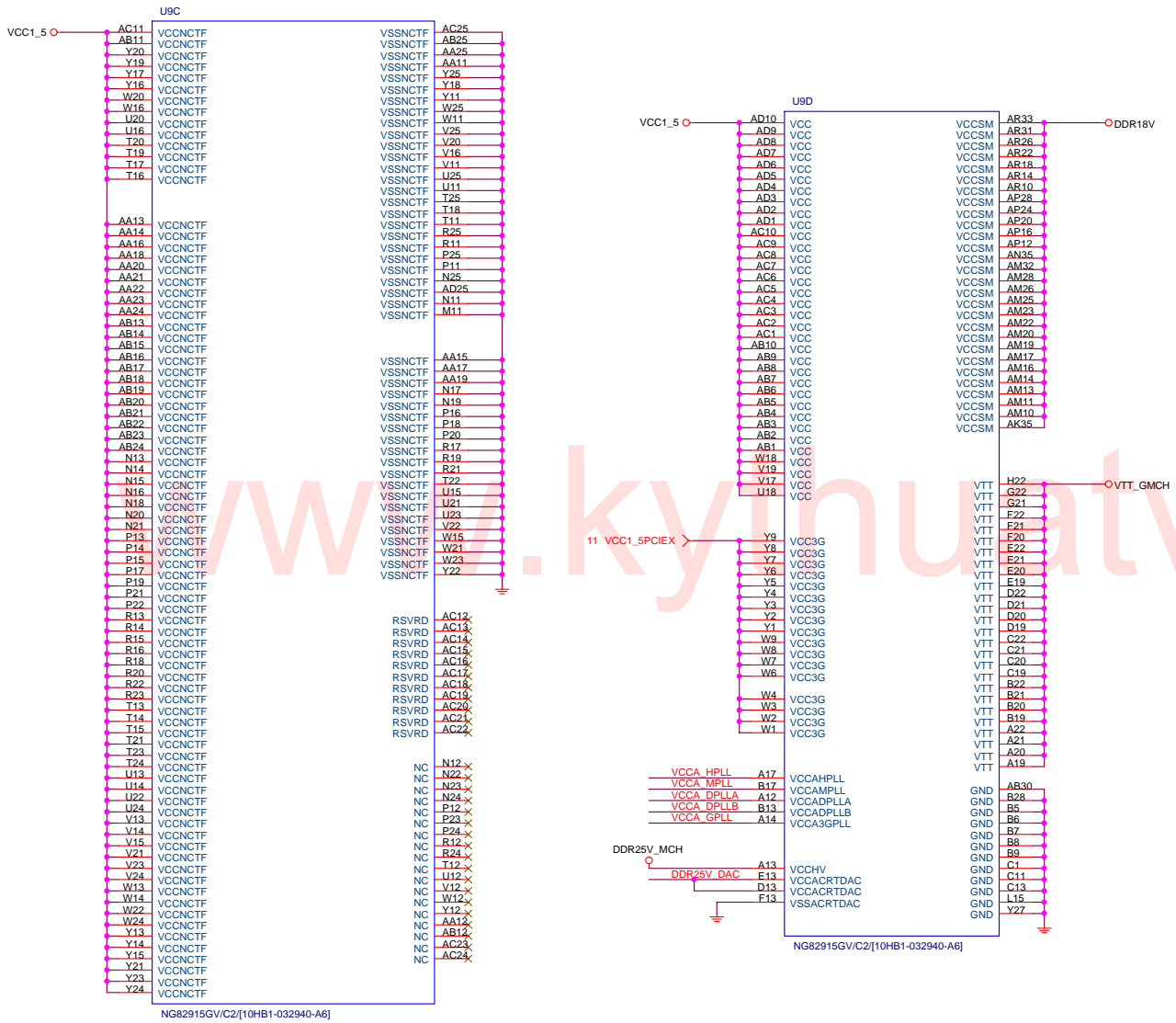

<b>GIGABYTE</b>			
Title	GMCH-PWR		
Size Custom	Document Number	<b>81915MD-GV</b>	
Date:	Friday, September 02, 2005	Sheet	14 of 35
Rev	<b>1.0</b>		

DG 1.0 change to 180ohm/0805 FB

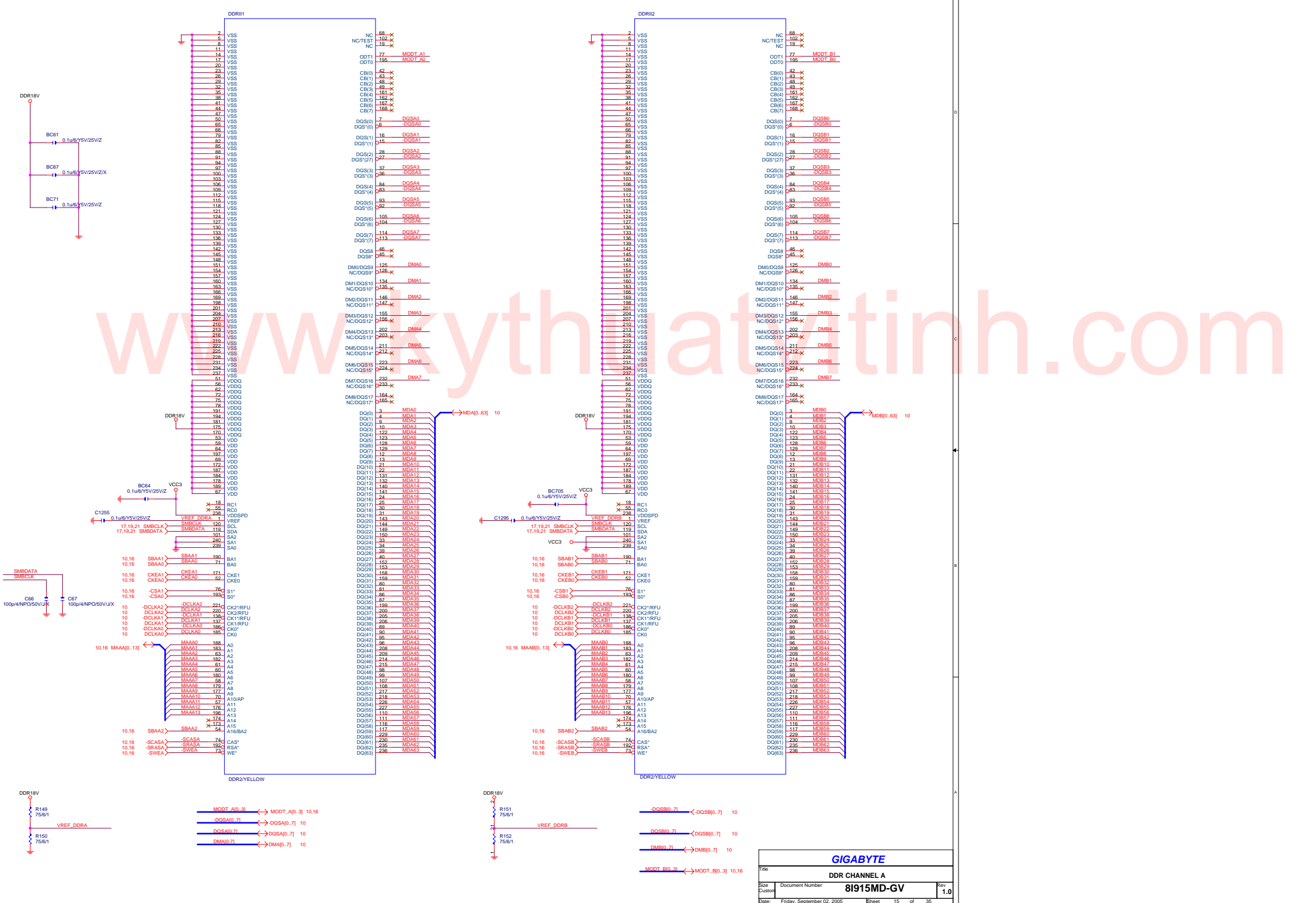

**GIGABYTE**

Title  
**DDR CHANNEL A**

Doc Number  
**81915MD-GV**

Date: Friday, September 02, 2005 Sheet: 15 of 35

Rev  
**1.0**

### DDRVTT Decouple

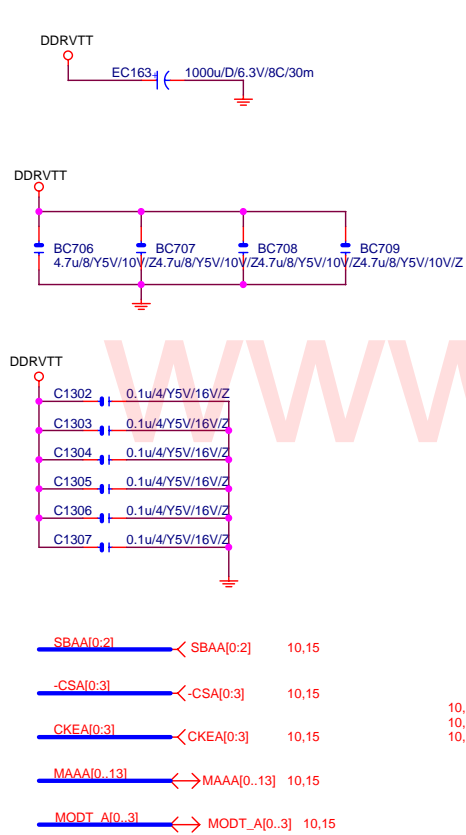

### DDR TERMINATION CHANNEL A

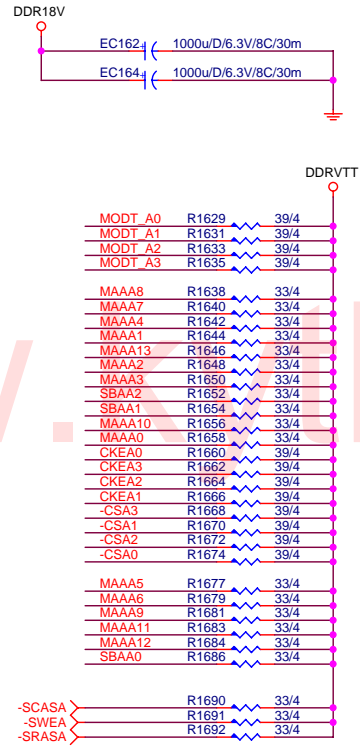

### DDRVTT Decouple

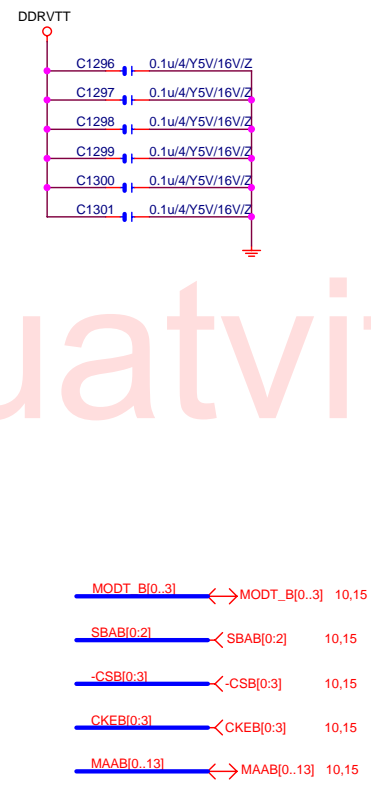

### CHANNEL B

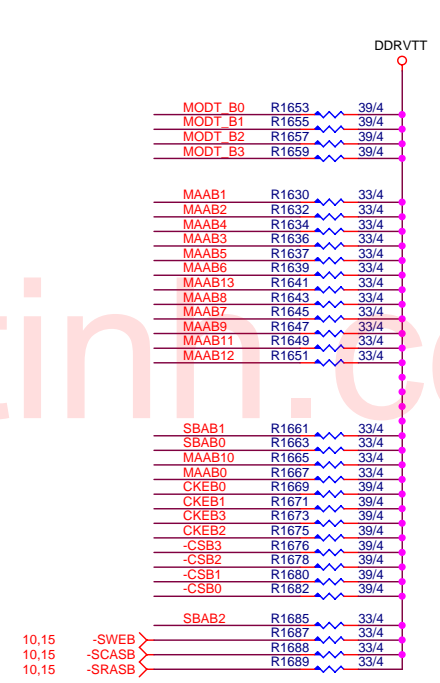



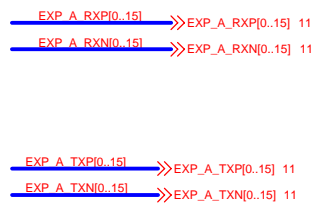
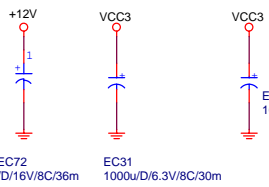

EXP_A_TXP0	C70	0.1u4Y5V/16V/Z/EXP_A_TXP0C
EXP_A_TXN0	C71	0.1u4Y5V/16V/Z/EXP_A_TXN0C
EXP_A_TXP1	C72	0.1u4Y5V/16V/Z/EXP_A_TXP1C
EXP_A_TXN1	C73	0.1u4Y5V/16V/Z/EXP_A_TXN1C
EXP_A_TXP2	C74	0.1u4Y5V/16V/Z/EXP_A_TXP2C
EXP_A_TXN2	C75	0.1u4Y5V/16V/Z/EXP_A_TXN2C
EXP_A_TXP3	C76	0.1u4Y5V/16V/Z/EXP_A_TXP3C
EXP_A_TXN3	C77	0.1u4Y5V/16V/Z/EXP_A_TXN3C
EXP_A_TXP4	C78	0.1u4Y5V/16V/Z/EXP_A_TXP4C
EXP_A_TXN4	C79	0.1u4Y5V/16V/Z/EXP_A_TXN4C
EXP_A_TXP5	C80	0.1u4Y5V/16V/Z/EXP_A_TXP5C
EXP_A_TXN5	C81	0.1u4Y5V/16V/Z/EXP_A_TXN5C
EXP_A_TXP6	C82	0.1u4Y5V/16V/Z/EXP_A_TXP6C
EXP_A_TXN6	C83	0.1u4Y5V/16V/Z/EXP_A_TXN6C
EXP_A_TXP7	C84	0.1u4Y5V/16V/Z/EXP_A_TXP7C
EXP_A_TXN7	C85	0.1u4Y5V/16V/Z/EXP_A_TXN7C
EXP_A_TXP8	C86	0.1u4Y5V/16V/Z/EXP_A_TXP8C
EXP_A_TXN8	C87	0.1u4Y5V/16V/Z/EXP_A_TXN8C
EXP_A_TXP9	C88	0.1u4Y5V/16V/Z/EXP_A_TXP9C
EXP_A_TXN9	C89	0.1u4Y5V/16V/Z/EXP_A_TXN9C
EXP_A_TXP10	C90	0.1u4Y5V/16V/Z/EXP_A_TXP10C
EXP_A_TXN10	C91	0.1u4Y5V/16V/Z/EXP_A_TXN10C
EXP_A_TXP11	C92	0.1u4Y5V/16V/Z/EXP_A_TXP11C
EXP_A_TXN11	C93	0.1u4Y5V/16V/Z/EXP_A_TXN11C
EXP_A_TXP12	C94	0.1u4Y5V/16V/Z/EXP_A_TXP12C
EXP_A_TXN12	C95	0.1u4Y5V/16V/Z/EXP_A_TXN12C
EXP_A_TXP13	C96	0.1u4Y5V/16V/Z/EXP_A_TXP13C
EXP_A_TXN13	C97	0.1u4Y5V/16V/Z/EXP_A_TXN13C
EXP_A_TXP14	C98	0.1u4Y5V/16V/Z/EXP_A_TXP14C
EXP_A_TXN14	C99	0.1u4Y5V/16V/Z/EXP_A_TXN14C
EXP_A_TXP15	C100	0.1u4Y5V/16V/Z/EXP_A_TXP15C
EXP_A_TXN15	C101	0.1u4Y5V/16V/Z/EXP_A_TXN15C

EXP_A_RXP0	SR1	0/4X	EXP_A_RXP0C
EXP_A_RXN0	SR2	0/4X	EXP_A_RXN0C
EXP_A_RXP1	SR3	0/4X	EXP_A_RXP1C
EXP_A_RXN1	SR4	0/4X	EXP_A_RXN1C
EXP_A_RXP2	SR5	0/4X	EXP_A_RXP2C
EXP_A_RXN2	SR6	0/4X	EXP_A_RXN2C
EXP_A_RXP3	SR7	0/4X	EXP_A_RXP3C
EXP_A_RXN3	SR8	0/4X	EXP_A_RXN3C
EXP_A_RXP4	SR9	0/4X	EXP_A_RXP4C
EXP_A_RXN4	SR10	0/4X	EXP_A_RXN4C
EXP_A_RXP5	SR11	0/4X	EXP_A_RXP5C
EXP_A_RXN5	SR12	0/4X	EXP_A_RXN5C
EXP_A_RXP6	SR13	0/4X	EXP_A_RXP6C
EXP_A_RXN6	SR14	0/4X	EXP_A_RXN6C
EXP_A_RXP7	SR15	0/4X	EXP_A_RXP7C
EXP_A_RXN7	SR16	0/4X	EXP_A_RXN7C
EXP_A_RXP8	SR17	0/4X	EXP_A_RXP8C
EXP_A_RXN8	SR18	0/4X	EXP_A_RXN8C
EXP_A_RXP9	SR19	0/4X	EXP_A_RXP9C
EXP_A_RXN9	SR20	0/4X	EXP_A_RXN9C
EXP_A_RXP10	SR21	0/4X	EXP_A_RXP10C
EXP_A_RXN10	SR22	0/4X	EXP_A_RXN10C
EXP_A_RXP11	SR23	0/4X	EXP_A_RXP11C
EXP_A_RXN11	SR24	0/4X	EXP_A_RXN11C
EXP_A_RXP12	SR25	0/4X	EXP_A_RXP12C
EXP_A_RXN12	SR26	0/4X	EXP_A_RXN12C
EXP_A_RXP13	SR27	0/4X	EXP_A_RXP13C
EXP_A_RXN13	SR28	0/4X	EXP_A_RXN13C
EXP_A_RXP14	SR29	0/4X	EXP_A_RXP14C
EXP_A_RXN14	SR30	0/4X	EXP_A_RXN14C
EXP_A_RXP15	SR31	0/4X	EXP_A_RXP15C
EXP_A_RXN15	SR32	0/4X	EXP_A_RXN15C

18	PCIE_OP0	PCIE_OP0	R3	0/4	EXP_A_TXP0C
18	PCIE_ON0	PCIE_ON0	R4	0/4	EXP_A_TXN0C
18	PCIE_OP1	PCIE_OP1	R12	0/4	EXP_A_TXP1C
18	PCIE_ON1	PCIE_ON1	R18	0/4	EXP_A_TXN1C
18	PCIE_OP2	PCIE_OP2	SR37	0/4	EXP_A_TXP2C
18	PCIE_ON2	PCIE_ON2	SR38	0/4	EXP_A_TXN2C
18	PCIE_OP3	PCIE_OP3	SR39	0/4	EXP_A_TXP3C
18	PCIE_ON3	PCIE_ON3	SR40	0/4	EXP_A_TXN3C

18	PCIE_IP0	PCIE_IP0	R5	0/4	EXP_A_RXP0C
18	PCIE_IN0	PCIE_IN0	R9	0/4	EXP_A_RXN0C
18	PCIE_IP1	PCIE_IP1	R13	0/4	EXP_A_RXP1C
18	PCIE_IN1	PCIE_IN1	R19	0/4	EXP_A_RXN1C
18	PCIE_IP2	PCIE_IP2	SR45	0/4	EXP_A_RXP2C
18	PCIE_IN2	PCIE_IN2	SR46	0/4	EXP_A_RXN2C
18	PCIE_IP3	PCIE_IP3	SR47	0/4	EXP_A_RXP3C
18	PCIE_IN3	PCIE_IN3	SR48	0/4	EXP_A_RXN3C

20:5:7:5:20

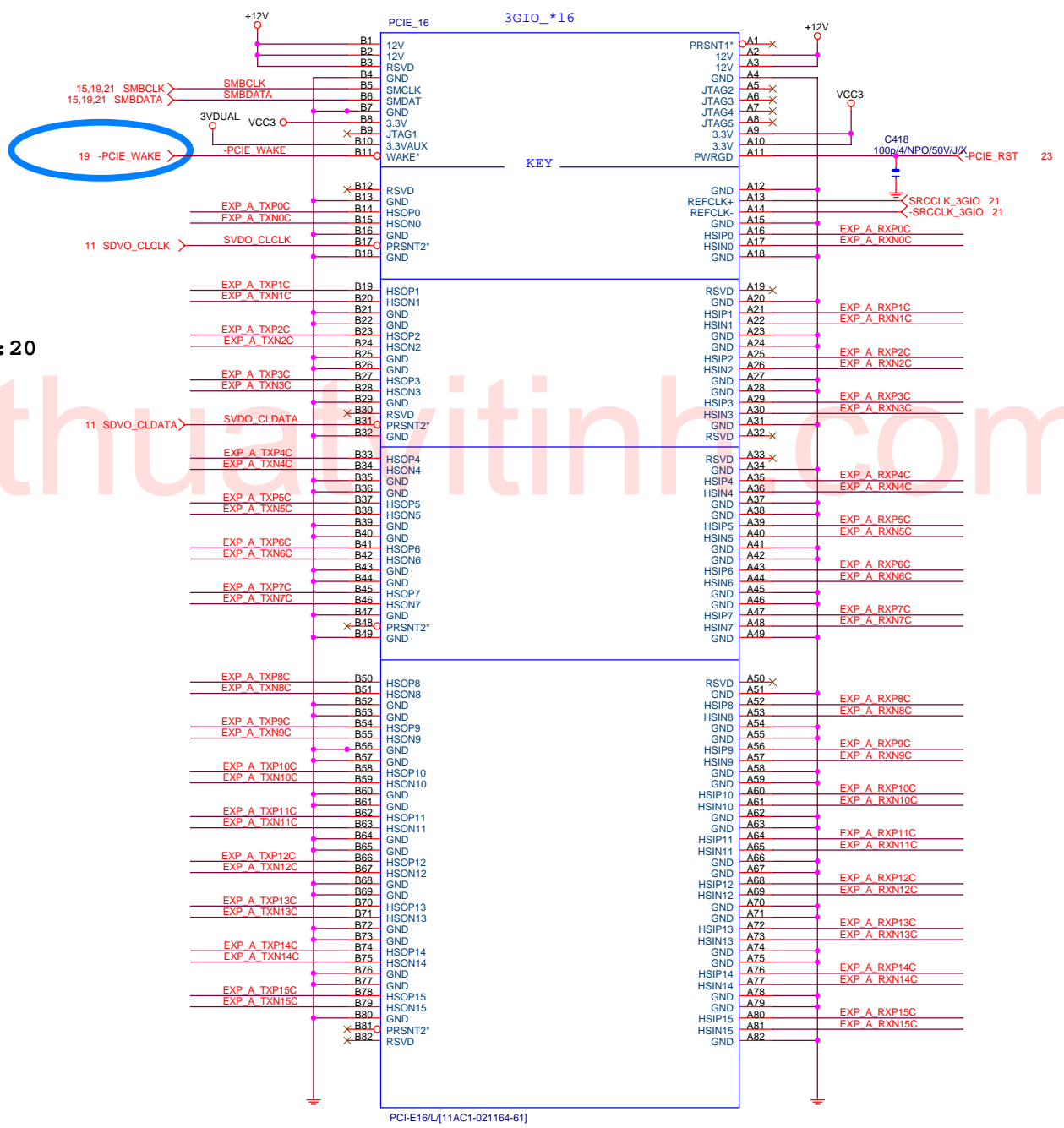

**GIGABYTE**

**PCI EXPRESS \* 16**

**8I915MD-GV**

Title		Rev	
Document Number		1.0	
Date:	Friday, September 02, 2005	Sheet	17 of 35

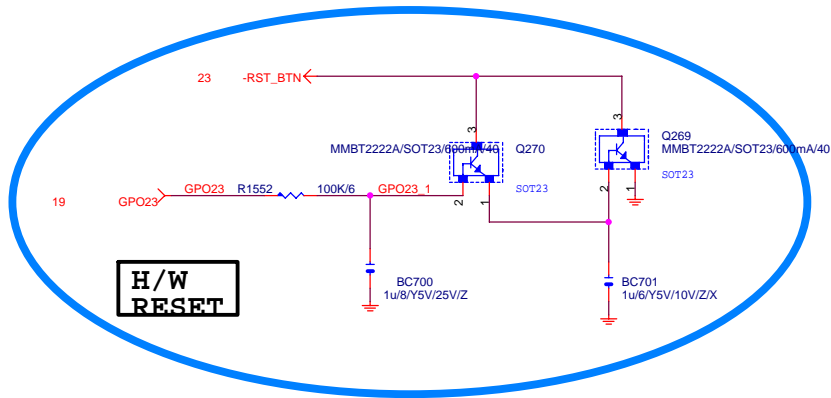

DMI Connection Note  
 GMCH TX Pin Need Connect to ICH6 RX Pin  
 ICH6 TX Pin Need Connect to GMCH RX Pin

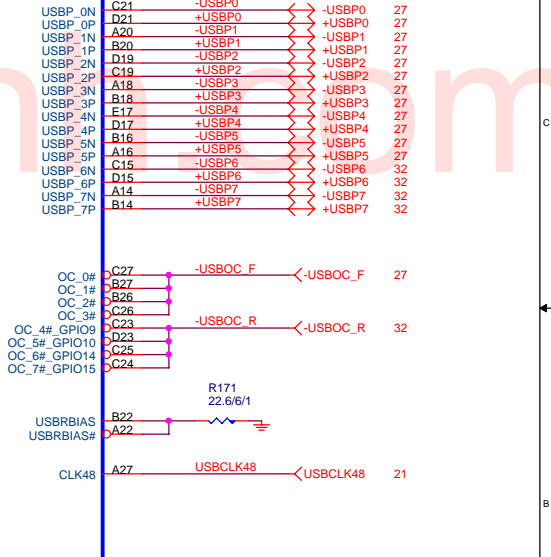
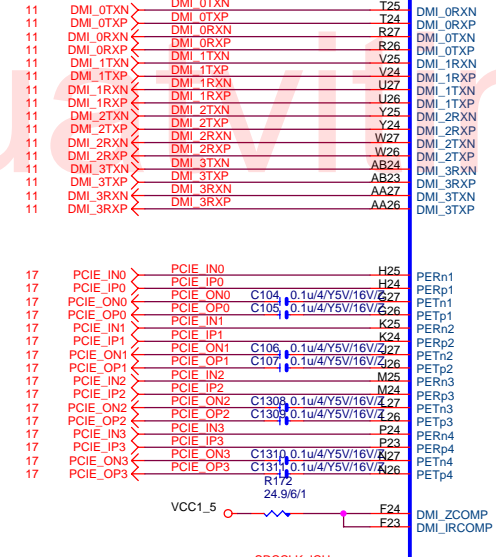
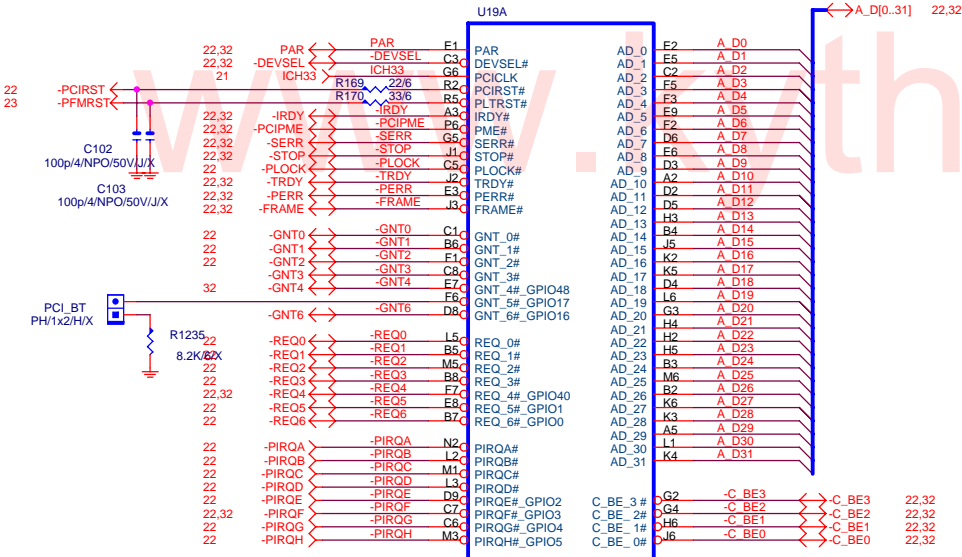

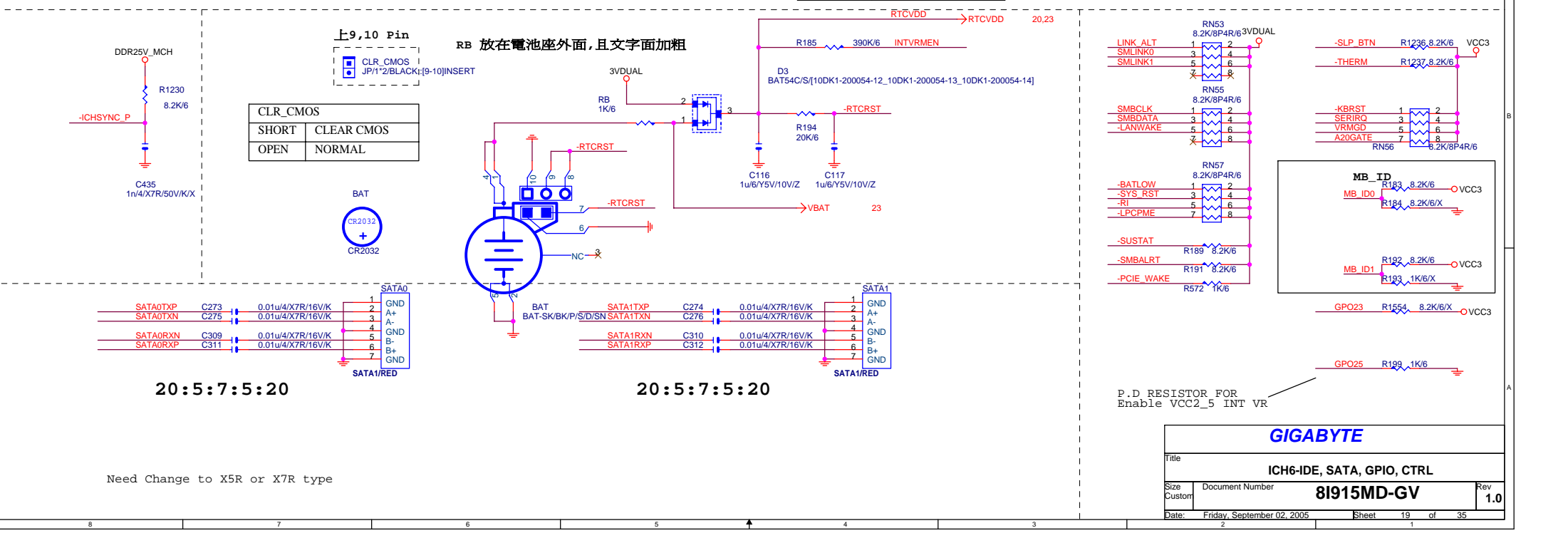
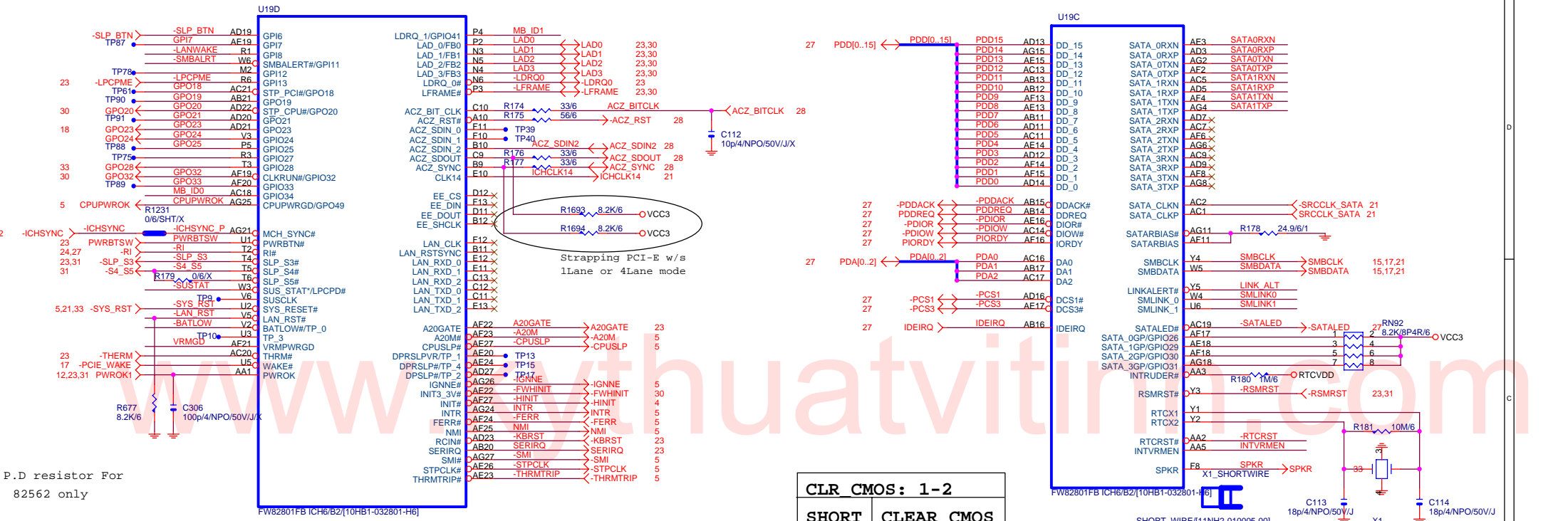

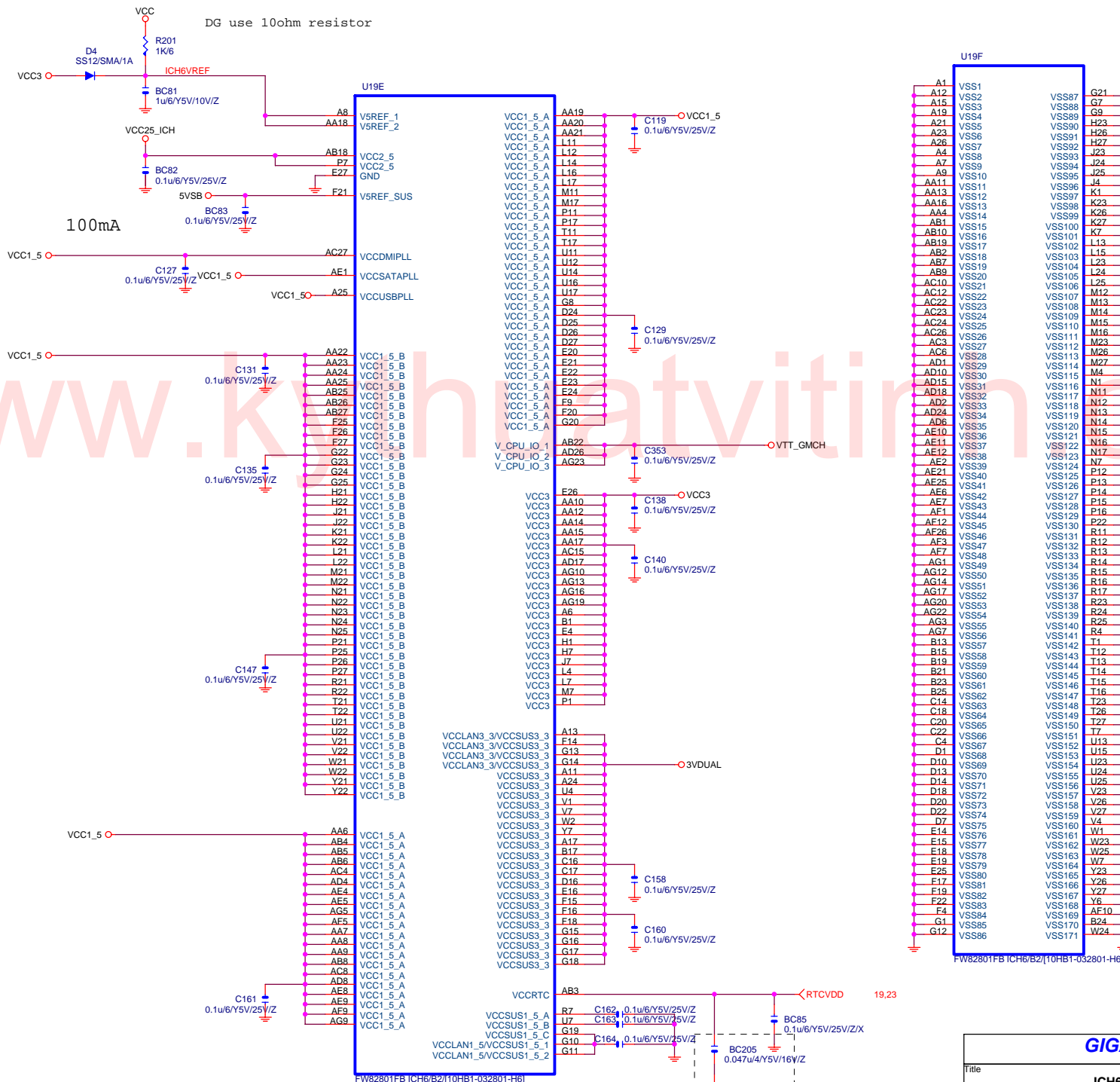

<b>GIGABYTE</b>		
<b>ICH6-PWR &amp; GND</b>		
Title	Document Number	Rev
	<b>8I915MD-GV</b>	<b>1.0</b>
Date:	Friday, September 02, 2005	Sheet 20 of 35

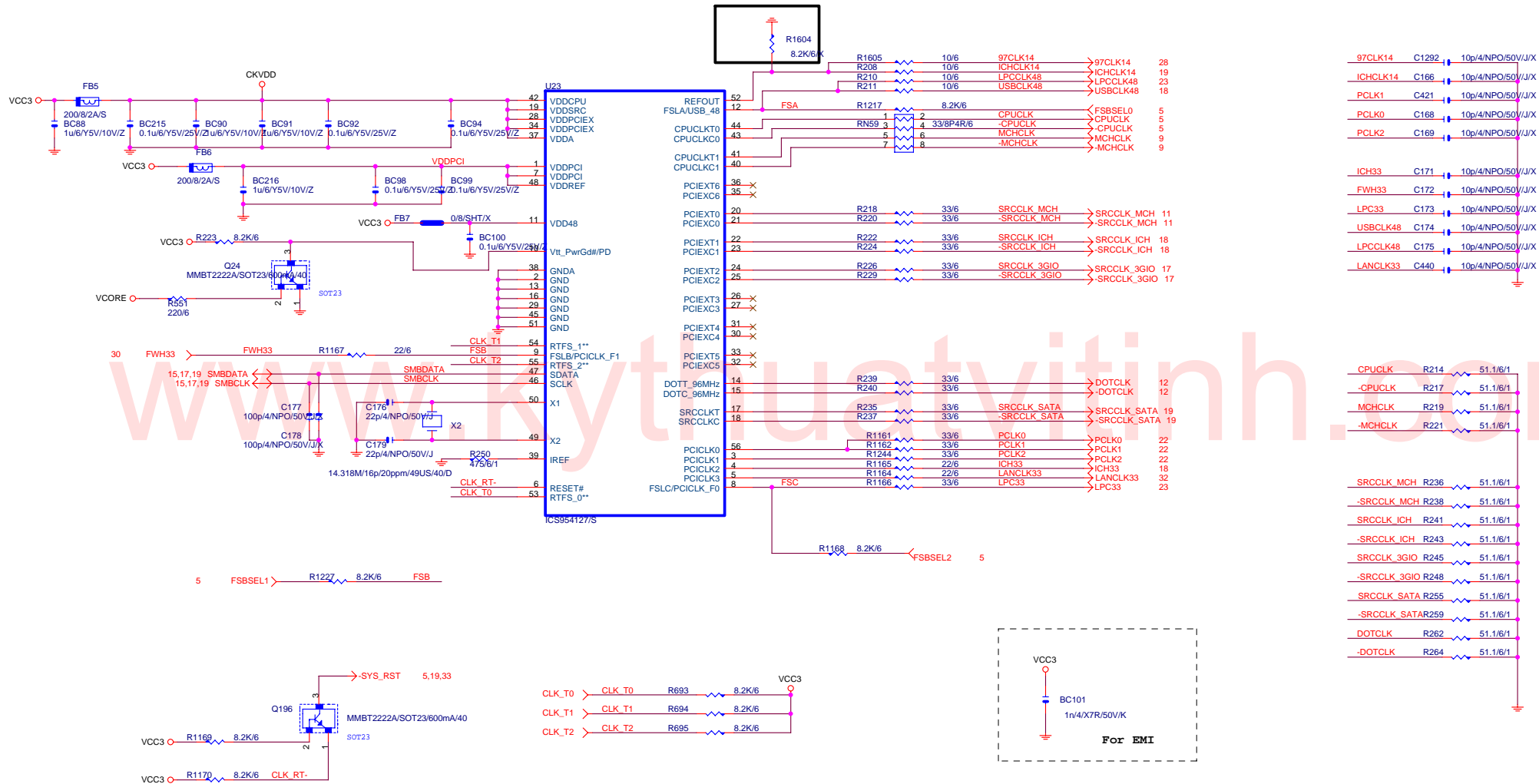

<b>GIGABYTE</b>		
Title <b>CK410M/GBT_CLK_GEN</b>		
Size	Document Number	Rev
Custom	<b>8915MD-GV</b>	<b>1.0</b>
Date:	Friday, September 02, 2005	Sheet 21 of 35

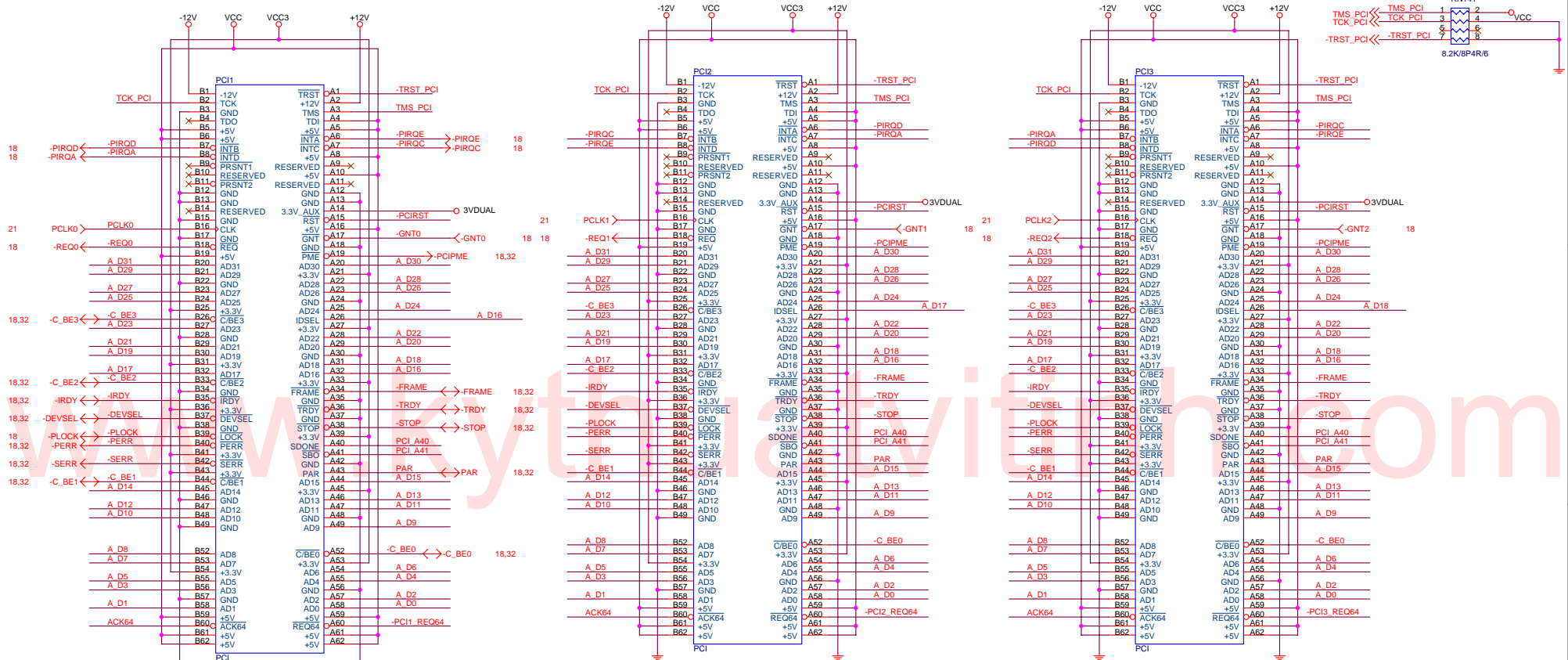

AD16 / -PIRQ(E-D-C-A) / -REQ0 / -GNT0

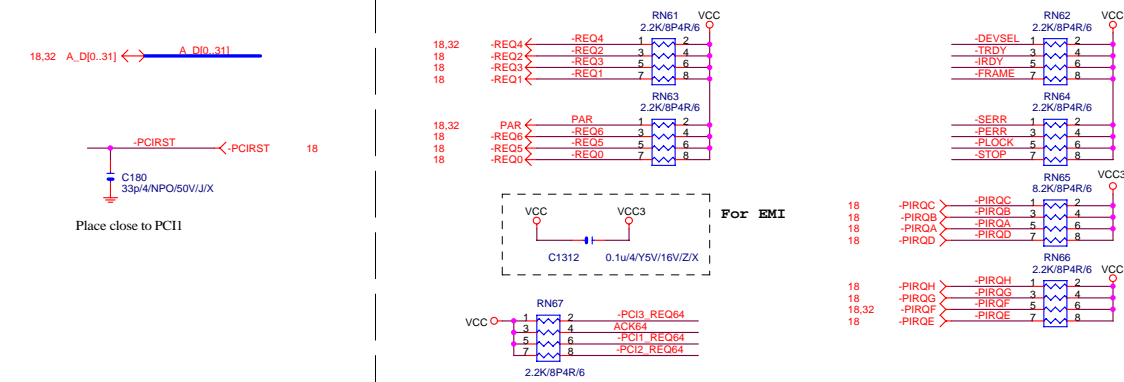

<b>GIGABYTE</b>		
<b>PCI SLOT</b>		
<b>8I915MD-GV</b>		
title	Document Number	Rev
		<b>1.0</b>
Date:	Friday, September 02, 2005	Sheet 22 of 35

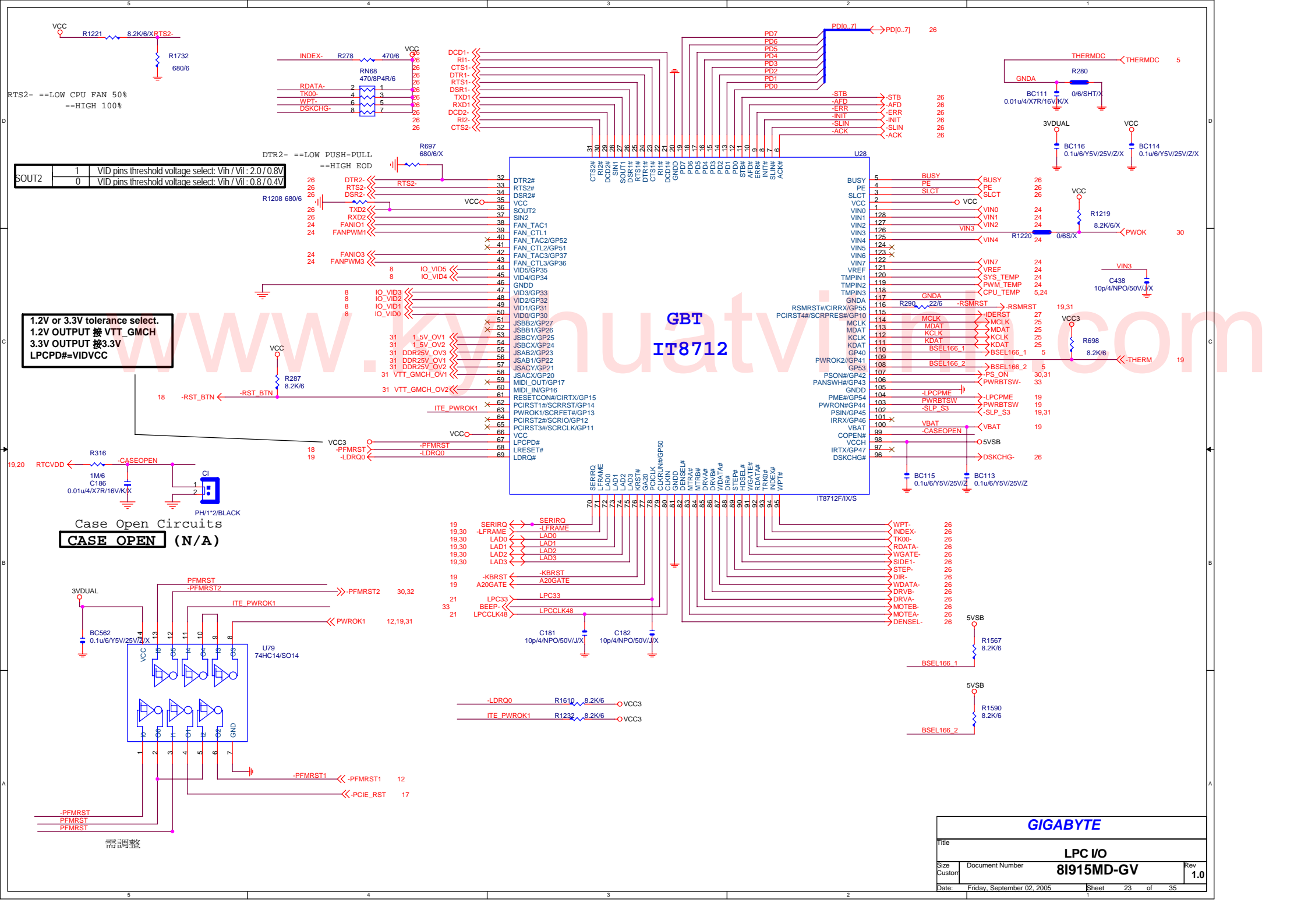

SOUT2	1	VID pins threshold voltage select: Vih / Vil : 2.0 / 0.8V
	0	VID pins threshold voltage select: Vih / Vil : 0.8 / 0.4V

1.2V or 3.3V tolerance select.  
 1.2V OUTPUT 接 VTT\_GMCH  
 3.3V OUTPUT 接 3.3V  
 LPCPD# = VIDVCC

GBT  
 IT8712

Case Open Circuits  
**CASE OPEN (N/A)**

<b>GIGABYTE</b>		
Title <b>LPC I/O</b>		
Size	Document Number	Rev
Custom	<b>8I915MD-GV</b>	<b>1.0</b>
Date:	Friday, September 02, 2005	Sheet 23 of 35

需調整

### TEMP. SENSE

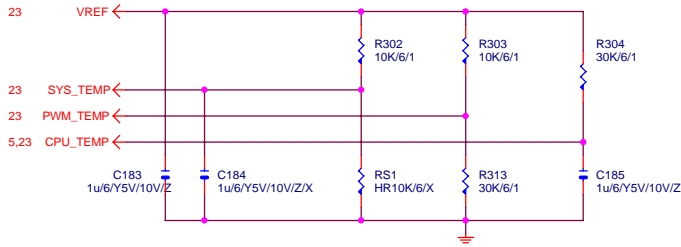

### VOLTAGE SENSE

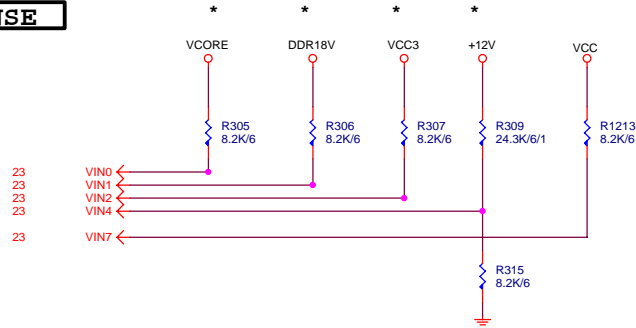

### CPU/SYS FAN

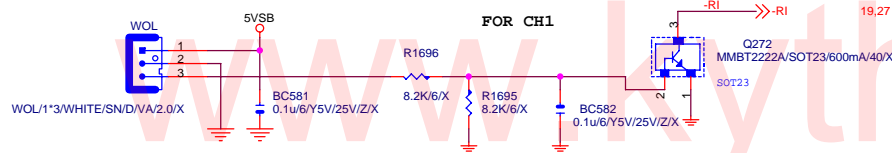

If use PBSS5240 lpcs : (non airflow)

- CPUFAN\_VCC=12V: Temp=40 deg
- CPUFAN\_VCC=11V: Temp=82 deg
- CPUFAN\_VCC=10V: Temp=70 deg
- CPUFAN\_VCC= 9V: Temp=110 deg
- CPUFAN\_VCC= 8V: Temp>200 deg

If use PBSS5240 lpcs : (with airflow)

- CPUFAN\_VCC=12V: Temp=33 deg
- CPUFAN\_VCC=11V: Temp=62 deg
- CPUFAN\_VCC=10V: Temp=86 deg
- CPUFAN\_VCC= 9V: Temp=117 deg
- CPUFAN\_VCC= 8V: Temp>122 deg

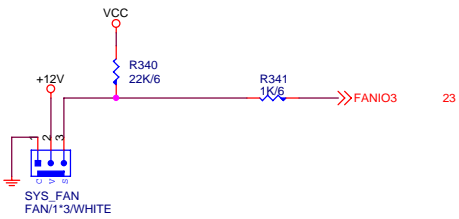
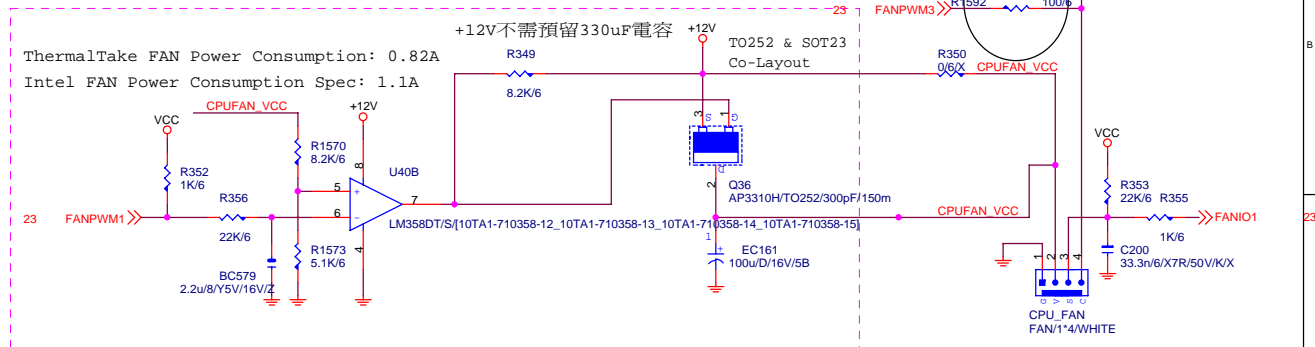

**GIGABYTE**

Title		
HWM/FANCI/BIOS		
Size	Document Number	Rev
Custom	8I915MD-GV	1.0
Date:	Friday, September 02, 2005	Sheet 24 of 35



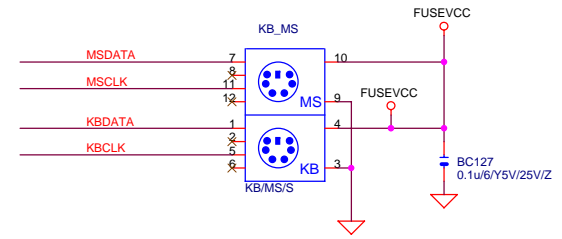
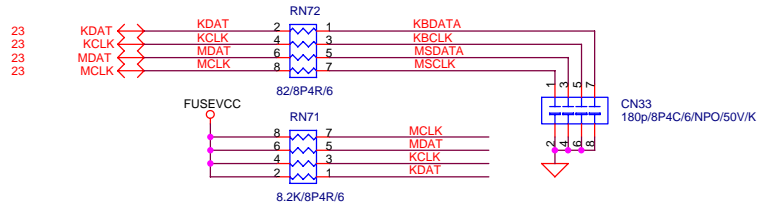

www.kythuatvithinh.com

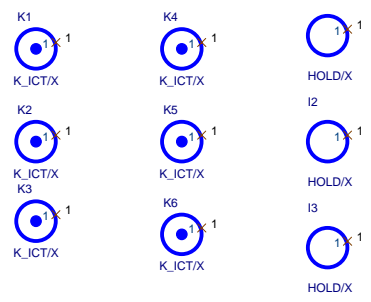
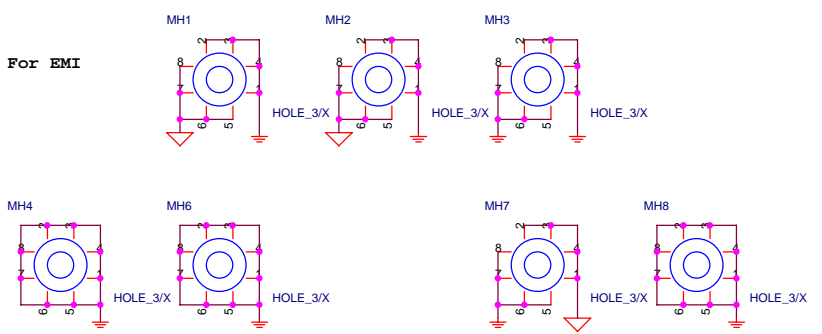
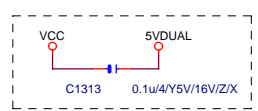

<b>GIGABYTE</b>		
Title <b>PS/2 KB &amp; MS</b>		
Size B	Document Number <b>8I915MD-GV</b>	Rev <b>1.0</b>
Date: Friday, September 02, 2005	Sheet 25	of 35

**COMA / COMB**

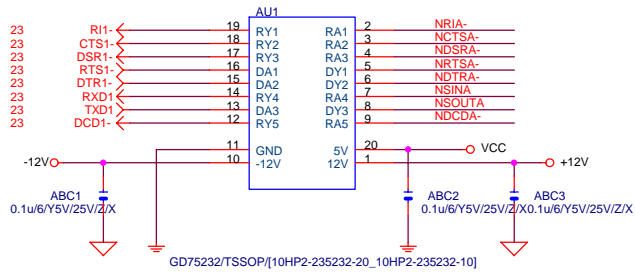

**COMA**

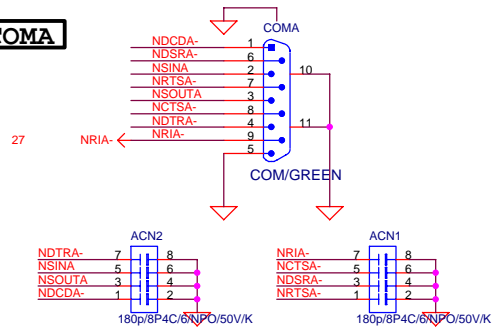

**INTERNAL COMB**

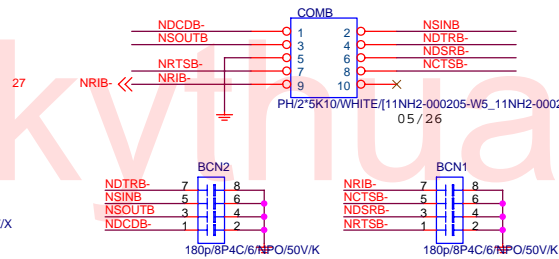
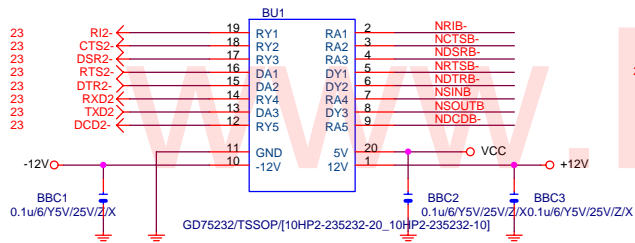

**LPT**

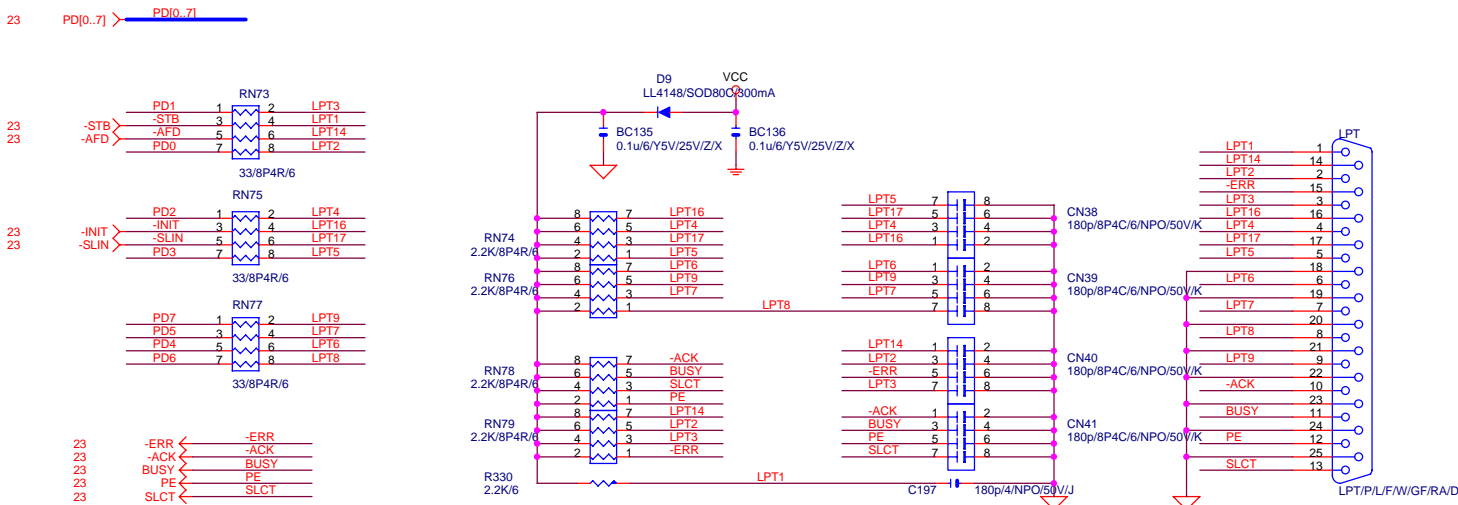

**FLOPPY**

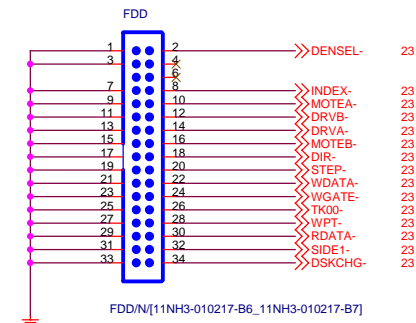

<b>GIGABYTE</b>		
Title <b>COM, LPT, FDD</b>		
Size B	Document Number <b>81915MD-GV</b>	Rev <b>1.0</b>
Date: Friday, September 02, 2005	Sheet 26	of 35

### FRONT USB1



20:7.5:7.5:7.5:20

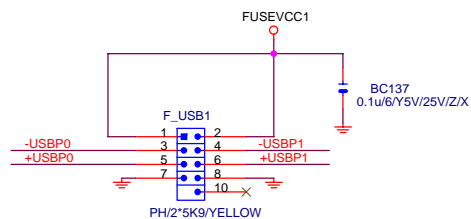

### FRONT USB2

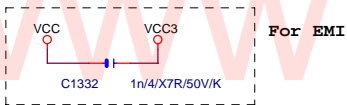
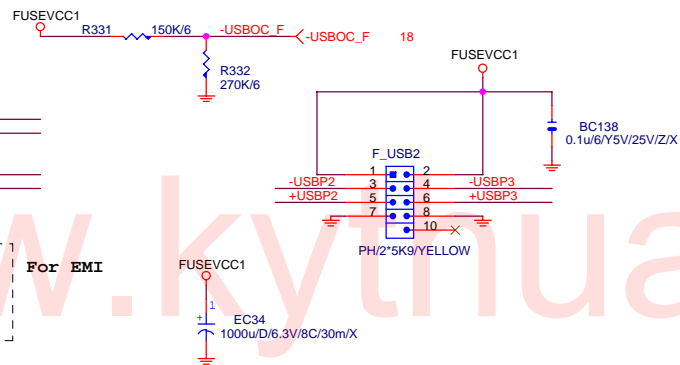
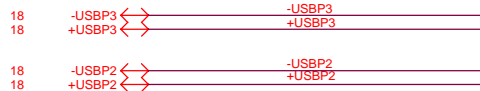

### RING IN

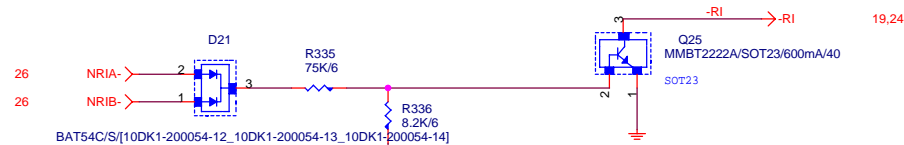

### IDE/SATA LED

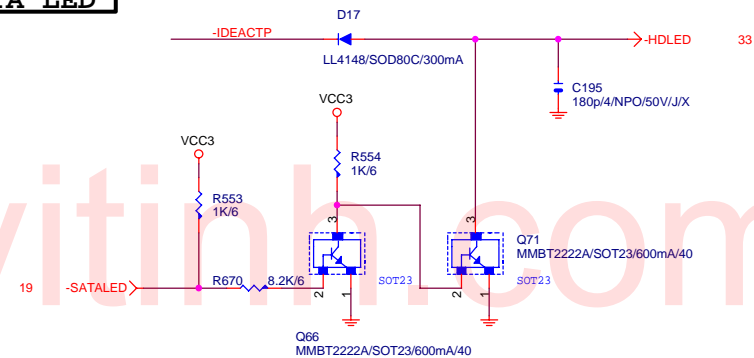

### FUSEVCC, GAMEVCC

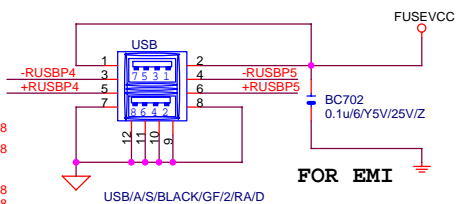
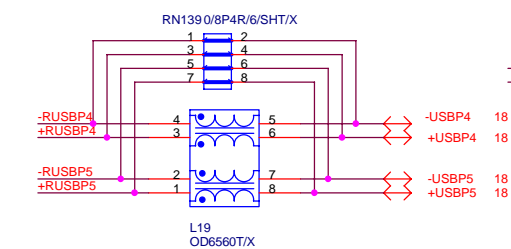

160MILS

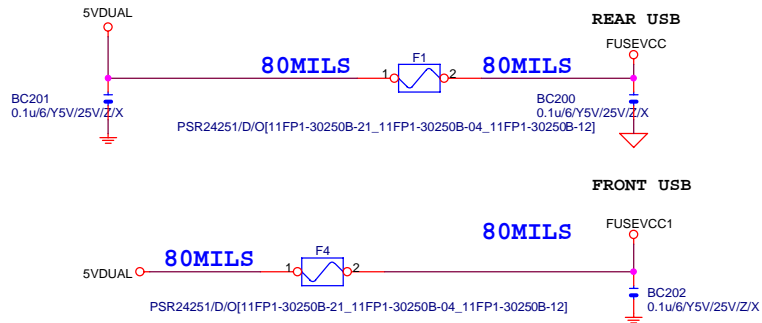

### IDE

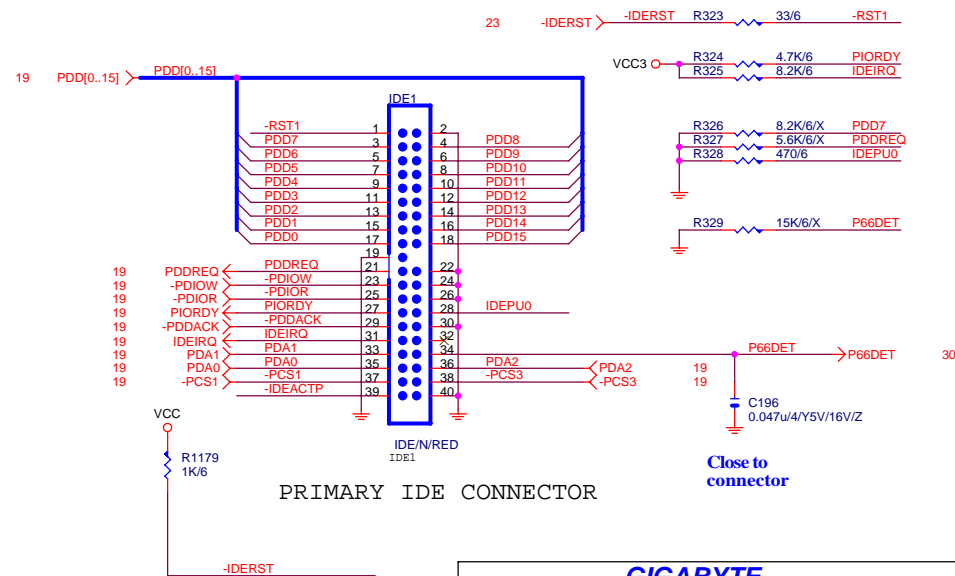

GIGABYTE

Title			FRONT/REAR USB CONNECTOR/IDE	
Size	Document Number	81915MD-GV		Rev
Custom			1.0	
Date:	Friday, September 02, 2005	Sheet	27	of 35

www.kythuatviti.com

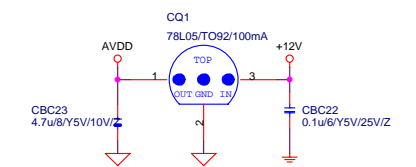
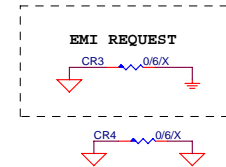
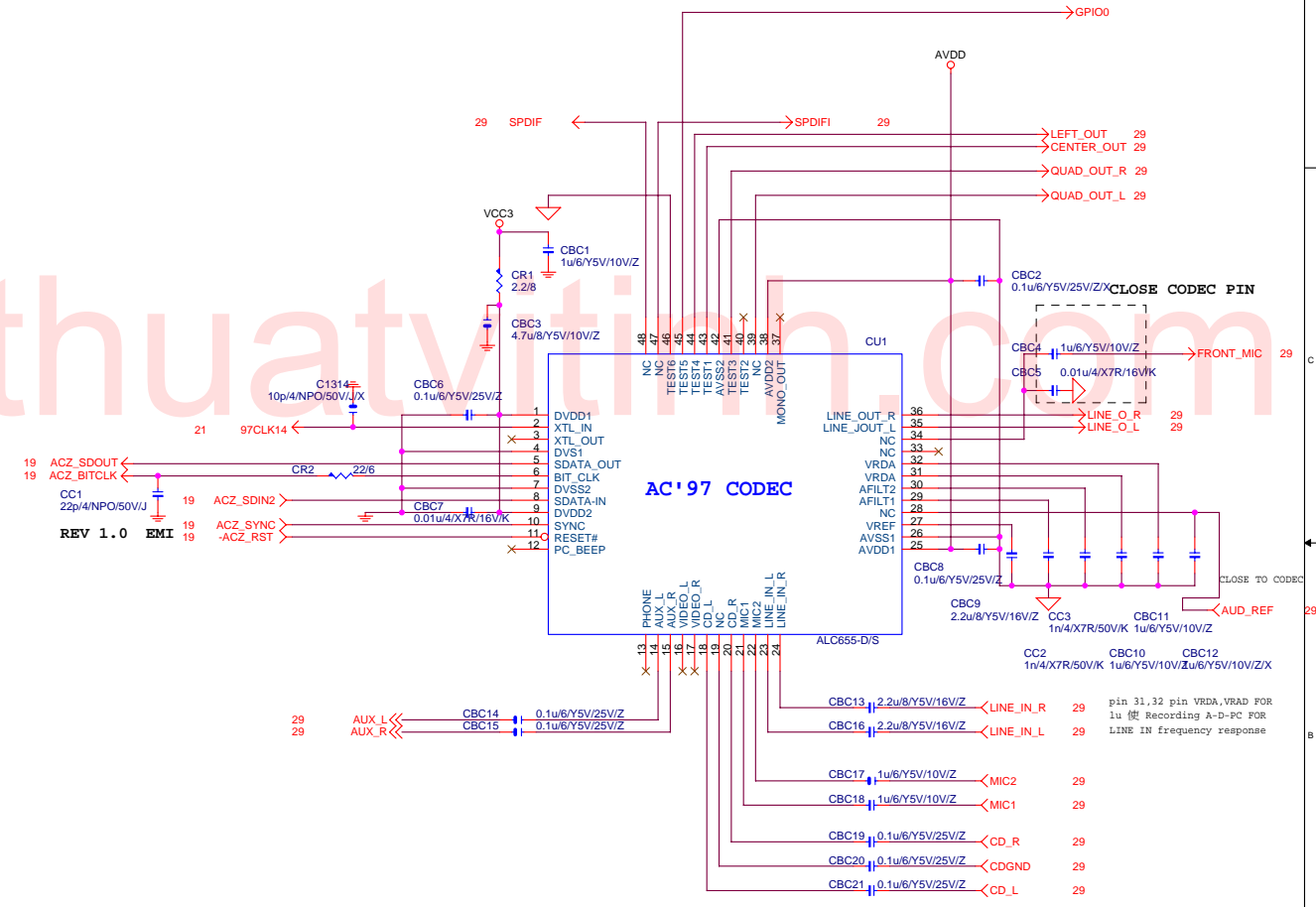

<b>GIGABYTE</b>		
<b>AUDIO (ALC655)</b>		
Title		
Size	Document Number	Rev
Custom	<b>8I915MD-GV</b>	<b>1.0</b>
Date:	Friday, September 02, 2005	Sheet 28 of 35

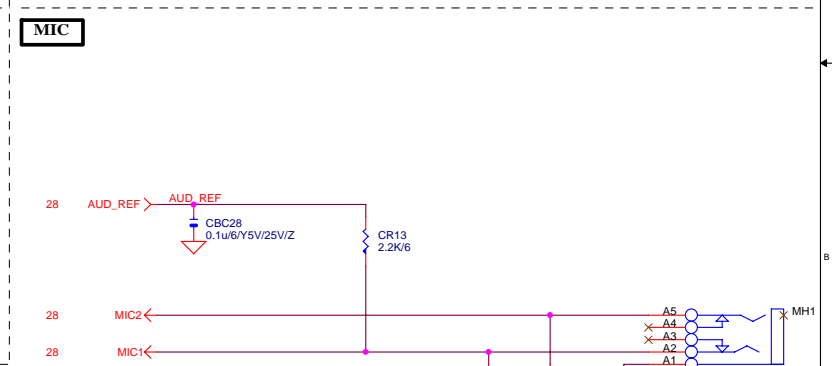
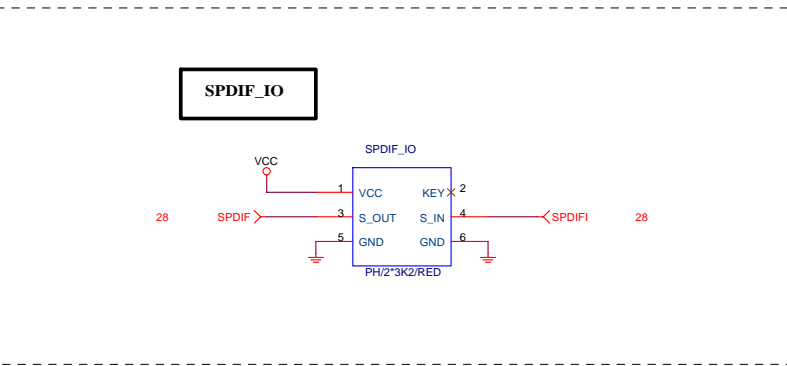
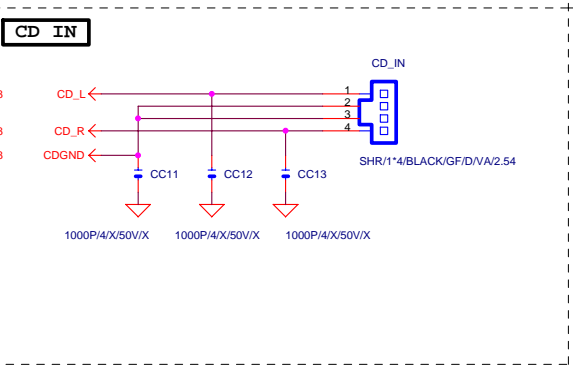
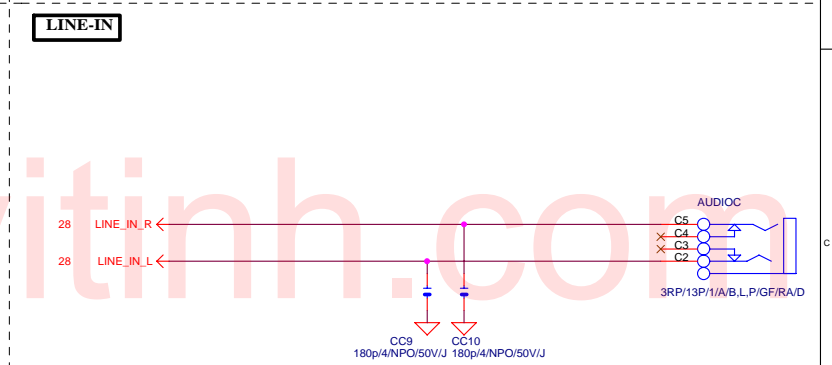
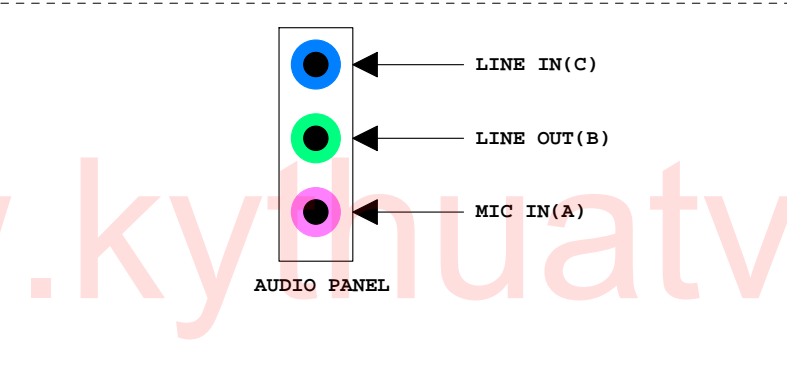
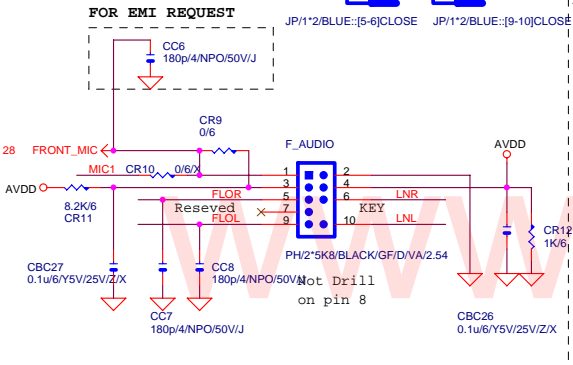
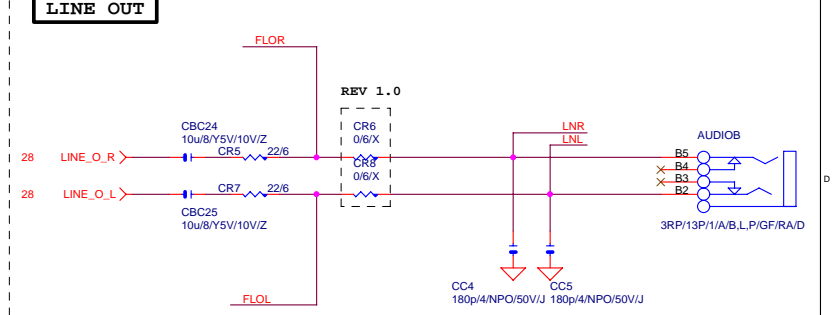
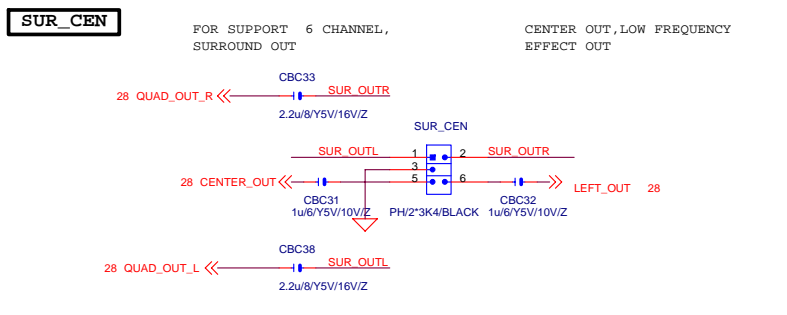
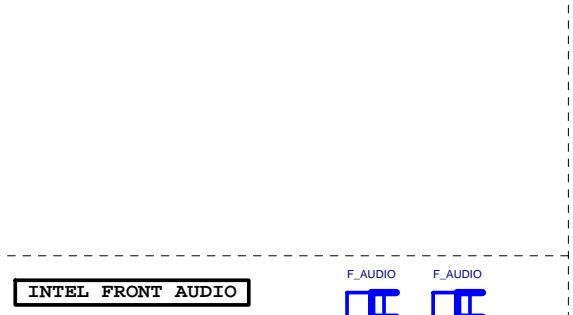

<b>GIGABYTE</b>			
<b>AUDIO OUTPUT</b>			
Size Custom	Document Number	Rev	1.0
<b>8I915MD-GV</b>		Date:	Friday, September 02, 2005
Sheet	29	of	35

# ATX POWER CONNECTOR

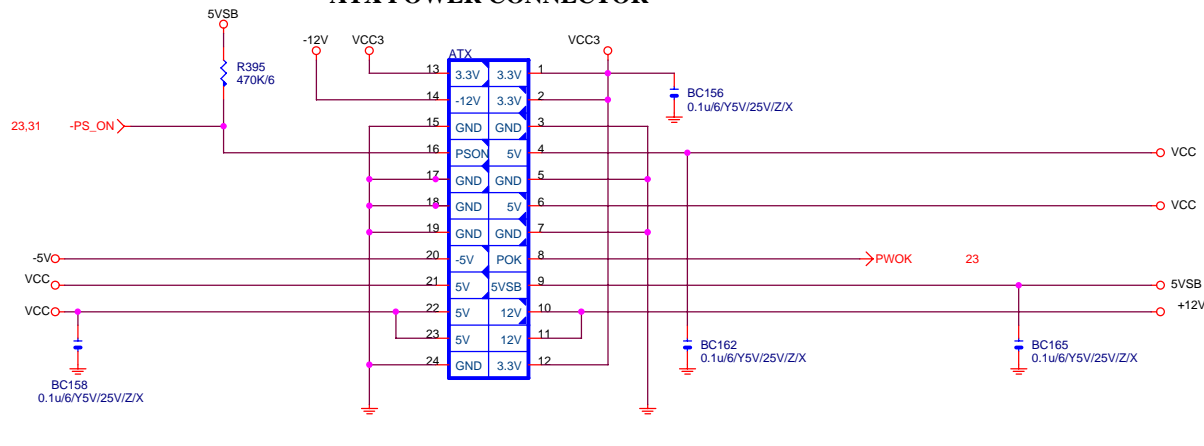

ATX-PW/2\*12/C/2H/IVORY/GF/VA[11NH4-020024-02\_11NH4-020024-03]

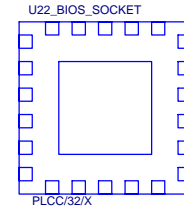
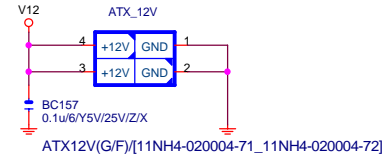

www.kythuativinh.com

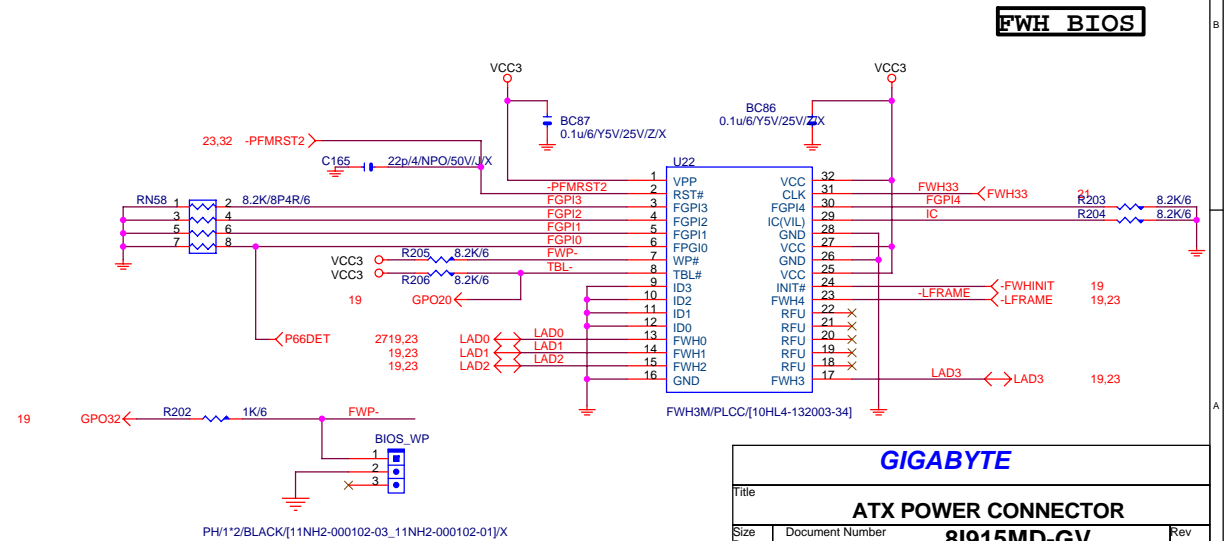

PH/1\*2/BLACK[11NH2-000102-03\_11NH2-000102-01]X

<b>GIGABYTE</b>		
<b>ATX POWER CONNECTOR</b>		
Size B	Document Number	Rev 1.0
	<b>8I915MD-GV</b>	
Date:	Friday, September 02, 2005	Sheet 30 of 35

5VDUAL CIRCUIT

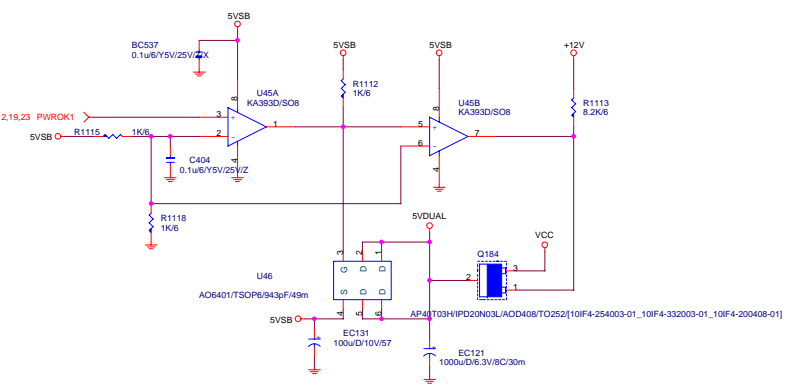

3VDUAL CIRCUIT

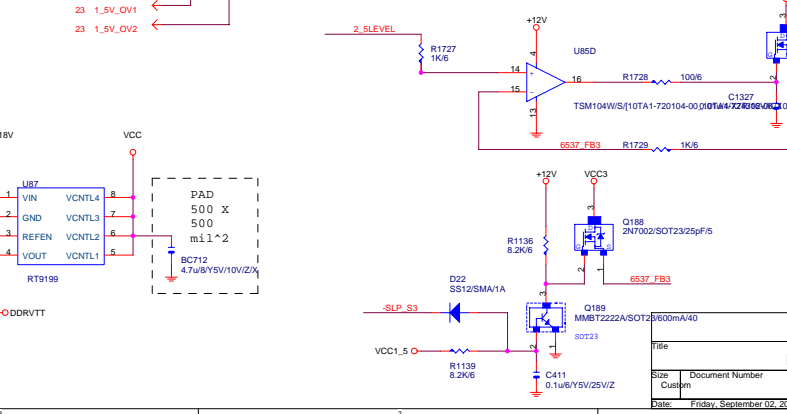
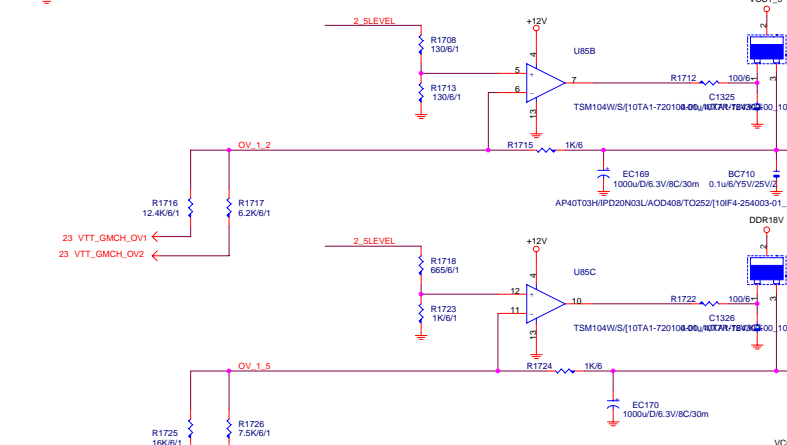
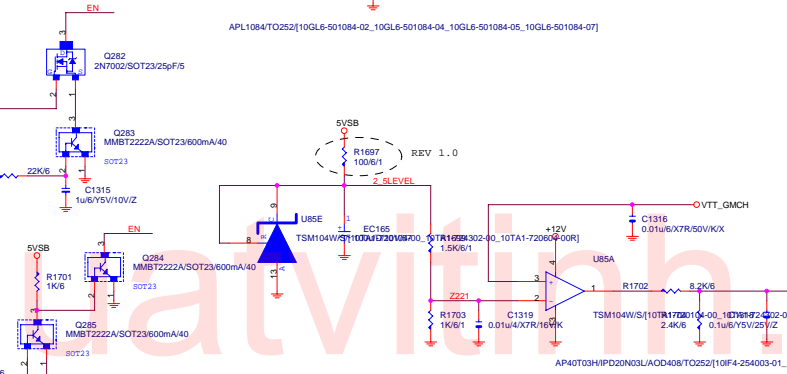
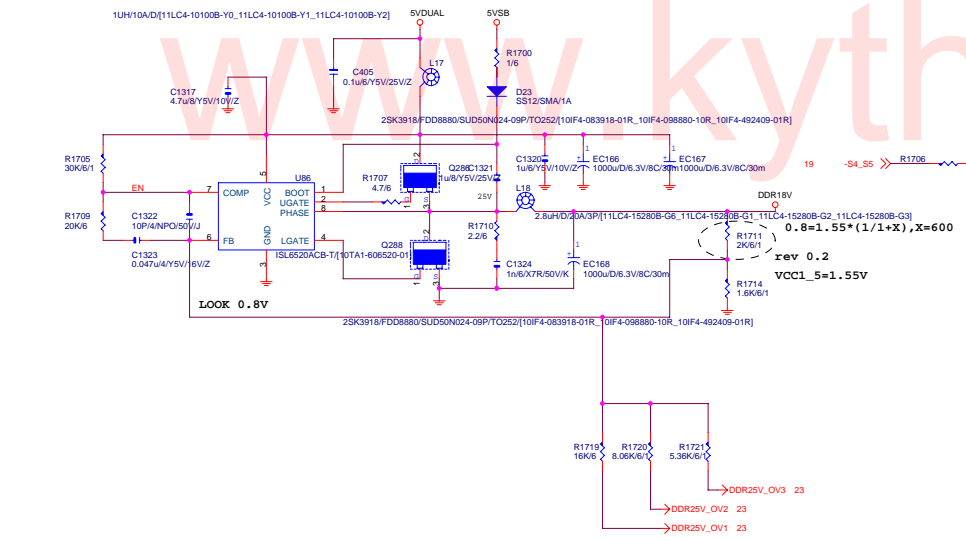
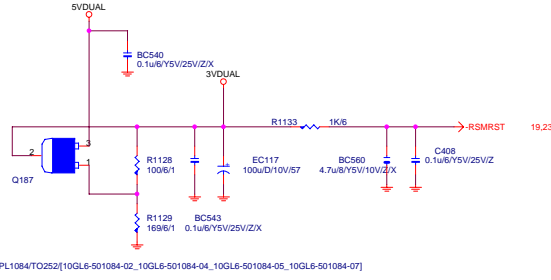

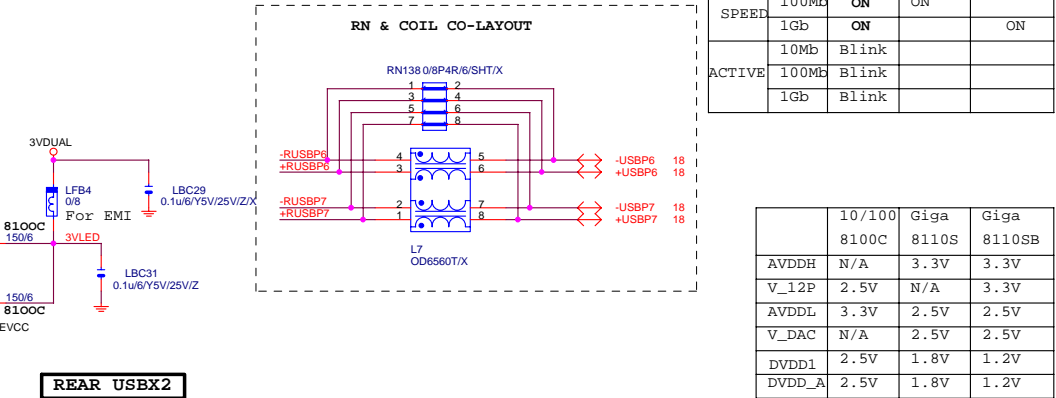
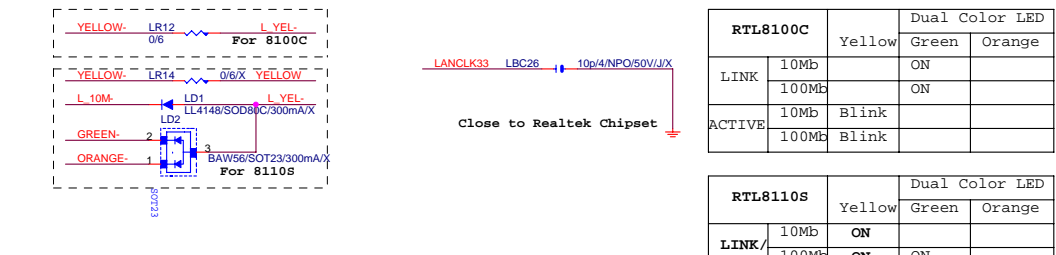
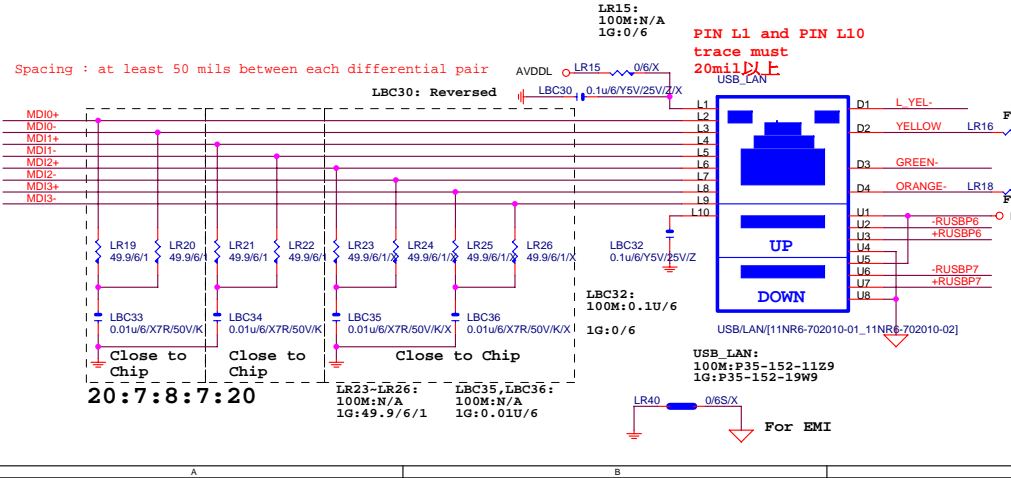
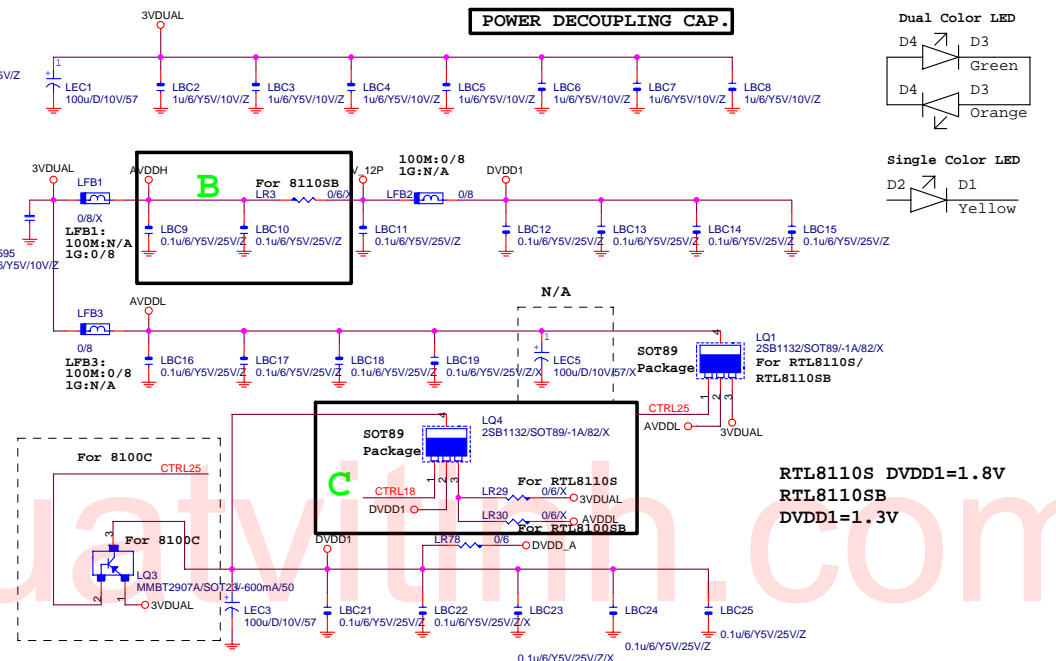
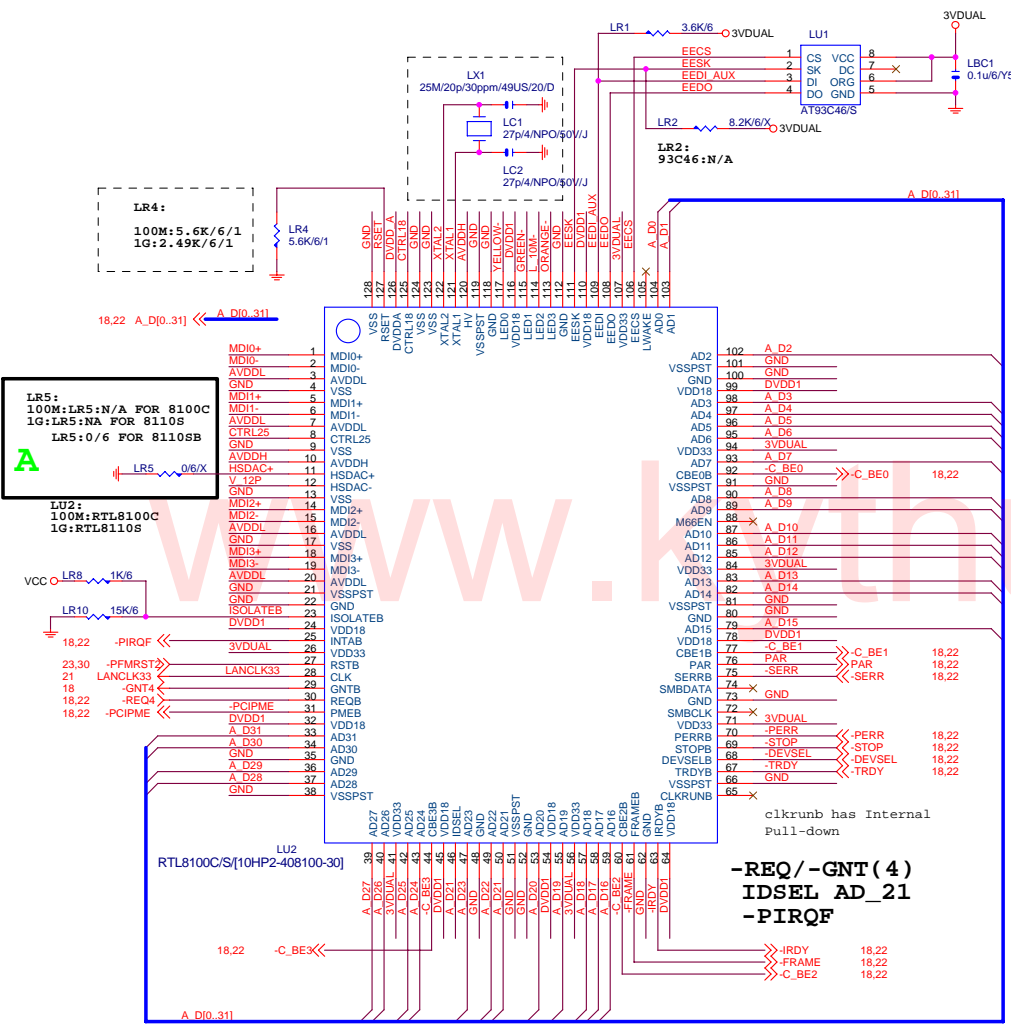

GIGABYTE			
LAN RTL8110S/8100C			
File	Document Number	Rev	
	81915MD-GV	1.0	
Date:	Friday, September 02, 2005	Sheet	32 of 35



# INTEL FRONT PANEL

3 PIN POWER LED  
LAYOUT PLACE CLOSE  
TO F\_PANEL

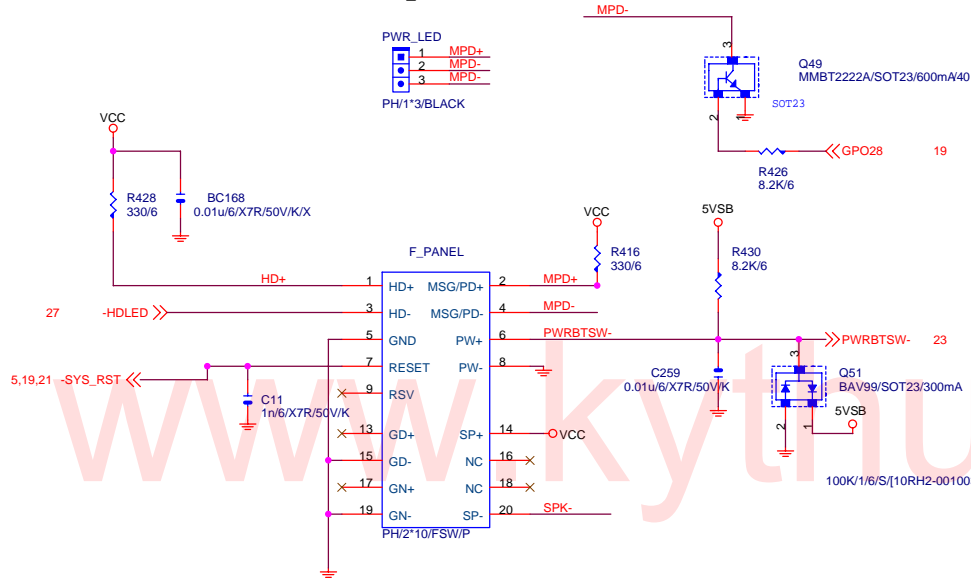

# PROCESSOR HOT

(N/A)

如果要用2N7002需注意OP output  
hi時的電壓是否遠大於2V。

asserted at 130 degree (RS2=720 ohm)  
deasserted at 115 degree (RS2=1270 ohm)  
KA393改為LM358，電源pin改接+12V，Prochot#溫度需重新調整之。

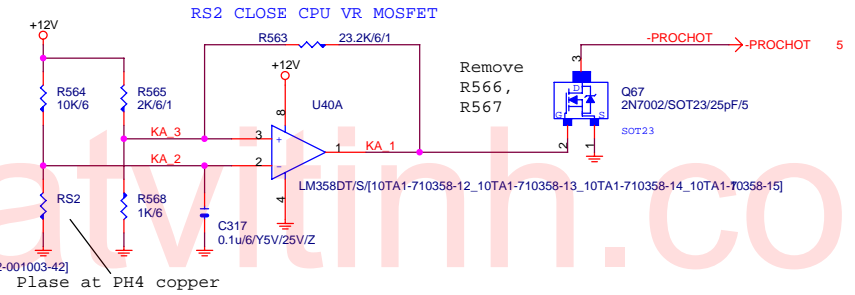

States for green LED NO1 GPO22 only S1 PROGRAMMING LOW

LED States	ACPI States	GPO28
ON	S1,S3	0
OFF	S0,S5	1

(GPO22 DEFAULT HIGH, main power)

States for a single-color power LED

LED States	ACPI States	GPO25	GPO27	GPO24
OFF	S1,S3,S5	1	1	NO1
Steady Green	S0	1	1	1
Blinking Green	S0(message waiting)	1	B	1

LED States	ACPI States	GPO25	GPO27	GPO22
OFF	S5	1	1	X
Steady Green	S0	1	1	1
Blinking Green	S0(message waiting)	1	B	1
Steady Yellow	S1,S3	1	0	NO1
Blinking Yellow	S1,S3(message waiting)	1	B	NO1

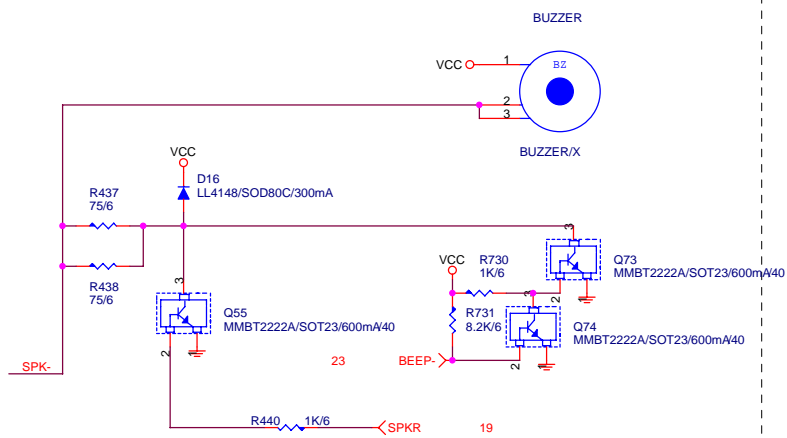

**GIGABYTE**

Title: **FRONT PANEL**  
 Size: Custom Document Number: **8I915MD-GV** Rev: **1.0**  
 Date: Friday, September 02, 2005 Sheet: 33 of 35



ICH6 GPIO Table:

NAME	PWR LANE	USAGE	NAME	PWR LANE	USAGE
GPI0	V5REF	M/B ID (-REQ6)	GPI41	VCC3	M/B ID
GPI1	V5REF	-REQ5	GPO48	VCC3	-GNT4
GPI2	V5REF	-PIRQE	GPO49	V-CPUIO	CPUPWOK
GPI3	V5REF	-PIRQF			
GPI4	V5REF	-PIRQG			
GPI5	V5REF	-PIRQH			
GPI6	VCC3	-SLP_BTN			
GPI7	VCC3	DUAL BIOS			
GPI8	3VDAUL	-LANWAKE			
GPI9	3VDAUL	-USBOC4			
GPI10	3VDAUL	-USBOC5			
GPI11	3VDAUL	-SMBALT			
GPI12	VCC3	ATX_DET			
GPI13	3VDAUL	-LPCPME			
GPI14	3VDAUL	-USBOC6			
GPI15	3VDAUL	-USBOC7			
GPO16	VCC3	CPU OV1 (-GNT6)			
GPO17	VCC3	-GNT5			
GPO18	VCC3	CPU OV2			
GPO19	VCC3	DUAL BIOS			
GPO20	VCC3	BIOS T-BLOCK			
GPO21	VCC3	DUAL BIOS			
GPO23	VCC3	DDR OV0			
GPI024	3VDAUL	GREEN_LED			
GPI025	3VDAUL	DDR OV1			
GPI26	VCC3	SATA_GP0			
GPI027	3VDAUL	+PWRLED			
GPI028	3VDAUL	-PWRLED			
GPI29	VCC3	SATA_GP1			
GPI30	VCC3	SATA_GP2			
GPI31	VCC3	SATA_GP3			
GPI032	VCC3	BIOS_WP			
GPI033	VCC3	AZALIA_DET			
GPI034	VCC3	M/B ID			
GPI40	V5REF	-REQ4			

PWROK/RESET Table:

ITE8712BHX PIN	NET NAME	TARGET
PIN62/-PCIRST1	-PCIE_RST	1. PCI-E * 1 Slot1 2. PCI-E * 1 Slot2 3. PCI-E * 1 Slot3 4. PCI-E * 16 Slot
PIN64/-PCIRST2	-PFMRST2	1. Onboard PCI Lan 2. Onboard 1394 Chip 3. OnBoard FWH
PIN65/-PCIRST3	-PFMRST1	1. Onboard PCI-E Lan 2. Onboard SATA Chip 3. GMCH
PIN115/-PCIRST4	-PFMRST -IDERST	Reserved For IDE
PIN63/PWROK1	PWROK1	1. GMCH 2. ICH6 3. 5VDUAL SWITCH 4. DPS CONTROL
PIN109/PWROK2	-THERM	1. ICH6

**GIGABYTE THCHNOLOGIES , INC.**

Title		GPIO/RESET TABLE	
Size	Document Number	81915MD-GV	Rev
Custom			1.0
Date:	Friday, September 02, 2005	Sheet	35 of 35